

SCALE **4WD** Series

BOLT-ON KIT
PARTIAL ASSEMBLY REQUIRED

BOOMRACING®
Your Radio Control Car Specialist

BRX02

1/10 4WD RADIO CONTROL CHASSIS KIT FOR D110

LEAF VERSION



THE SCALE PERFORMANCE CONTINUES

Congratulations on your new ownership of this truly extraordinary chassis – the Boom Racing BRX02. As a start, we would like to introduce you to your customized license plates and vehicle VIN number system to identify your vehicle, which are both uniquely yours. All BRX02 chassis kits are numbered and all Boom Racing vehicles with Vehicle Identification Number (VIN) are unique.

As the original owner, you are eligible to receive a special promotion at each of the events being attended by Boom Racing. Once your vehicle is registered online (<https://www.boomracingrc.com/BRX02/register>), the chassis is officially registered to you and no one else can claim it. This will help with any future updates and can be used to notify you of new options in the future. We believe that this will encourage enthusiasm and interaction between owners and we hope that it will boost attendance at events to push the hobby industry further down the road.

Included with your BRX02 chassis kit is a set of original license plates, commonly used in the UK during the D110 production period. The plates consist of two groups of alphanumeric characters. From left to right, the characters consist of:

- The first two characters signify the BRX02 chassis
- The next letter identifies the chassis type - **S** for Shocks / **L** for Leaf
- The fourth character identifies the wheelbase or vehicle type – **1** for 110 / **9** for 90
- A three or four-letter sequence starting from 001, which uniquely distinguishes each of the vehicles displaying the same initial four-character chassis type and wheelbase sequence.



Scan to register your BRX02



A Bolt-On Kit means parts of the chassis are pre-assembled and require minor assembly for completion. The factory assembled parts offer convenience for builders eager to get started. The BRX02 kit includes factory pre-built axles, transmission, transfer case and shocks. Shocks require oil to be filled (included).



⚠ NOT RECOMMENDED FOR CHILDREN UNDER 14 ⚠

THIS CHASSIS KIT IS NOT A TOY. FIRST-TIME BUILDER SHOULD SEEK ADVICE FROM PEOPLE HAVING BUILDING EXPERIENCE IN ORDER TO ASSEMBLE THE MODEL CORRECTLY. ASSEMBLE THIS KIT ONLY IN PLACES OUT OF CHILDREN'S REACH.



The Scale 4WD Series is Boom Racing's line of scale based 4WD R/C products geared towards realistic appearance.

BEFORE YOU PROCEED

Congratulations! Owning the BRX02 is a truly special experience.

Carefully read and follow all instructions to prevent serious damage to your model. Failure to follow these instructions will be considered abuse and/or neglect.

Study the instructions thoroughly before assembly.

There are many small screws, nuts and similar parts. Assemble them carefully referring to the drawings. Follow the steps exactly as shown to build the vehicle correctly without issues.

If you decide to return the BRX02, do not begin assembly. Your hobby dealer will not accept a model for return or exchange after you have started assembly.

Boom Racing offers Spare Parts & Upgrade Options for improved performance. Visit our website (<https://www.boomracingrc.com>) or your local Boom Racing dealer for assistance. Please note that specifications, availability and price are subject to change without notice.

SAFETY PRECAUTIONS

All of us here at Boom Racing want you to enjoy your new vehicle. Operate your BRX02 sensibly and with care, and it will be exciting, safe and fun for you and those around you. Failure to operate your BRX02 in a safe and responsible manner may cause damage and injury and void your warranty.

Follow these outlined rules for safe radio control operation

- Read carefully and fully understand the instructions before assembly.
- ***This model is not intended for use by children (minors) under 14 years of age without the supervision of a responsible and knowledgeable adult who should also read the instructions.***
- When assembling this kit, extra care should be taken to avoid personal injury. Keep out of reach of small children.
- Avoid running the vehicle in crowded areas and near small children.
- BRX02 can be very fast and quiet. It could cause injury to those unaware of its presence.

Inspect Your BRX02 Before and After Operation

- Make sure that all screws and nuts are properly tightened.
- Use thread lock on screws for any metal on metal surface.
- Adjust steering servo and trim so that the BRX02 runs straight with transmitter in neutral.
- Disconnect/remove all batteries after operation.
- Replace any batteries that have been dented, are bloated, or have frayed wires, short circuits can cause fire.
- Completely remove sand, mud, dirt etc after use to prolong the life of the BRX02.
- Maintain bearings by cleaning or replacing them regularly.

WARRANTY

Boom Racing's One (1) Year Factory Limited Warranty – A Peace Of Mind Right From The Start

WHO IS COVERED

This warranty is extended to the original end-user that registers it online (<https://www.boomracingrc.com/BRX02/register>) only, whether purchased or received as a gift.

FACTORY LIMITED WARRANTY

What Is Covered and For How Long

Boom Racing warrants that all new products are free from defects in manufacturing, materials and workmanship for a period of one (1) year from date of retail purchase. The receipt or invoice at the time of purchase is your proof of purchase and is required for Boom Racing to honor any warranty.

What Is Not Covered

It does not cover defects or malfunction caused by user error of assembly, damages due to normal wear and tear, failure to follow operating instructions, misuse or abuse, users' failure to perform routine maintenance, or use with products with which is not intended to be used. It also does not cover damages caused by unauthorized alteration, modification or repair. It does not cover cosmetic or incidental damages. Boom Racing does not warrant or provide service or support for any third party products.

The JX mini servo warranty will be void if it is disassembled.

What We Will Do

We will, at our discretion, repair or replace any product free of charge that is incorrectly made or proves to be defective in material or workmanship during the warranty period. If your product is no longer being manufactured or is out of stock, we may replace your product with a comparable or improved product at our option.

What We Will Not Do

We will not pay for shipping, insurance or transportation charges from you to us, or any import fees, duties and taxes.

What To Do To Obtain Warranty Service

To obtain warranty service for products purchased from a third-party, retail or directly from Boom Racing you must return the product with proof of purchase using the following procedures:

1. Contact Boom Racing Customer Support for specific warranty instructions via our website, by email, telephone, or our social media accounts:

- Online @: <https://www.boomracingrc.com/contact-us>
- Email: sales@boomracingrc.com
- Telephone: 1-209-676-8880
- Facebook Messenger: (www.fb.com/boomracingrc) or Instagram: DM @boom_racing

You may be asked to complete a warranty service request form. A copy of your purchase receipt may be required.

2. Our Customer Support may ask you to return and ship the defective product back to us. Label and ship the product, freight prepaid, to the address provided by Boom Racing; and

3. Place any necessary return authorization number prominently on the outside of the return packaging. Return packaging not bearing a return authorization number where required may be refused.

Boom Racing reserves the right to final decision, change or modify this warranty without notice.

Equipment Required

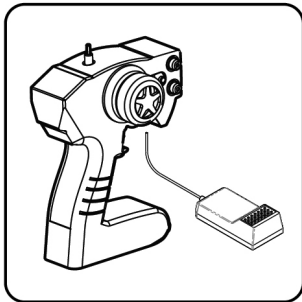

3CH Radio

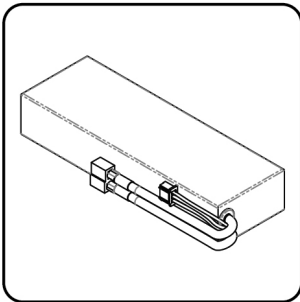

Battery

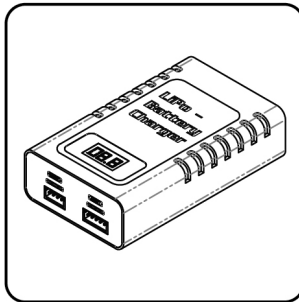

Charger

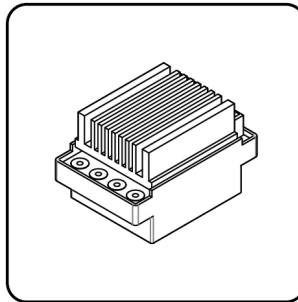

ESC

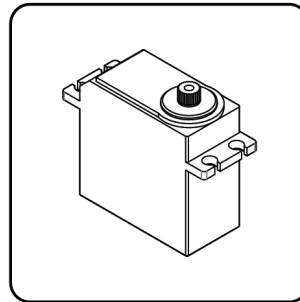

Steering Servo

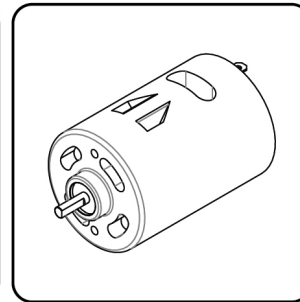

540/550 Motor

Tools Recommended

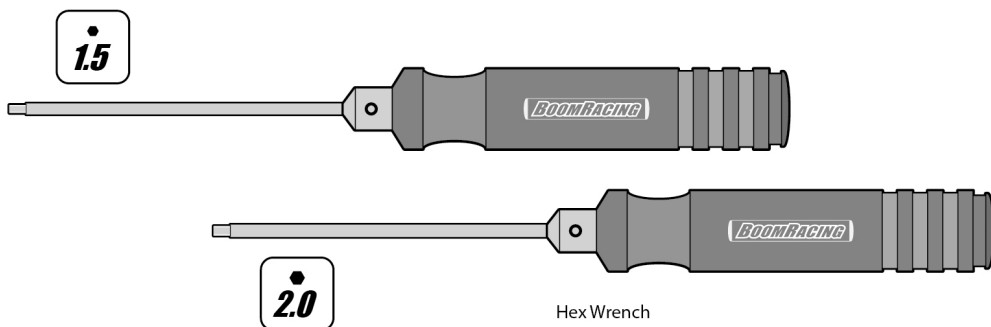

Hex Wrench

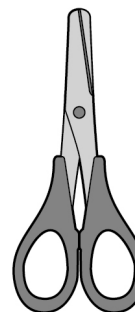

Scissors



Hobby Knife



Slot Screwdriver

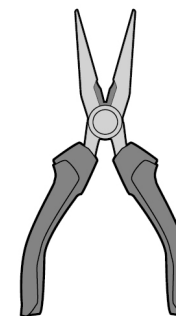

Long Nose Pliers



Thread Lock

Apply thread lock to places shown by this mark.
Apply thread lock first, then assemble.
(Do Not Use Red Loctite)



Black Graphite Grease

Lubricate all gears.
Apply grease to the places shown by this mark.
Apply grease first, then assemble.



Silicone Grease

Lubricate all moving parts including joints and bearings.
Apply grease to the places shown by this mark.
Apply grease first, then assemble.



Shock Oil

Apply shock oil to the places shown by this mark.



Apply Double Side Tape



Item not included.



Pay attention to note on page.

PART LOCATION MAP (TOP)

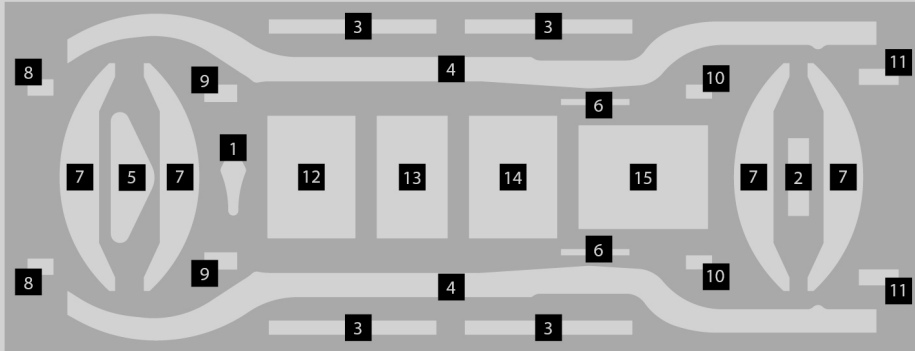

1

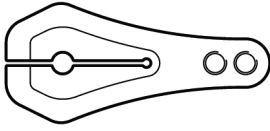

Servo Horn B - 25T x 1
#BRLC7055

2



Shock End Pivot x 8
#BRW750310



Joint Retainer x 8
#BRSHJR

3



KUDU™ 90mm Scale Shock Absorber x 4
#BRSH0090

4

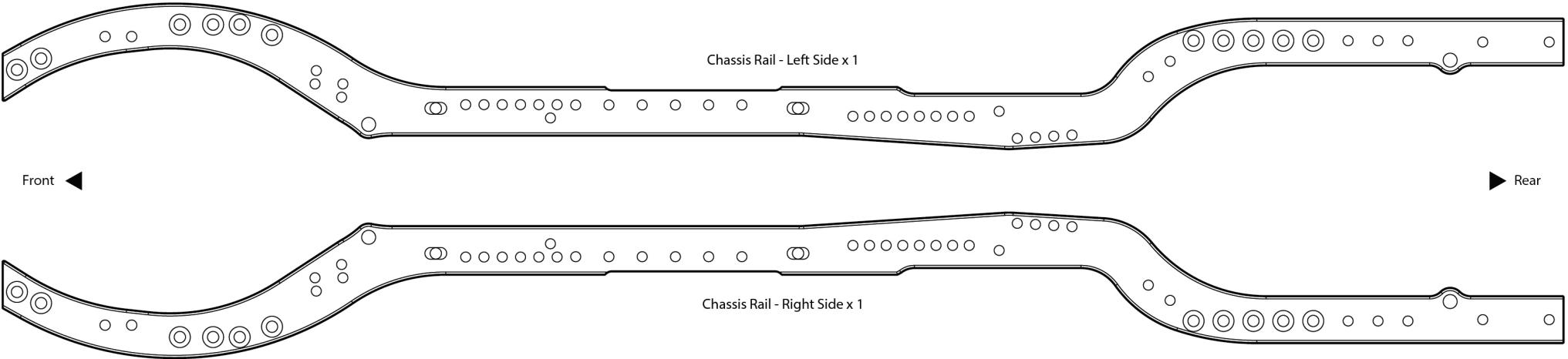

Chassis Rail - Left Side x 1

Chassis Rail - Right Side x 1

Front ◀

▶ Rear

#BRX020011

5



Front Anti-Wrap Bar x 2
#BRX020027



Brass Washer x 4
#BRX020030

6

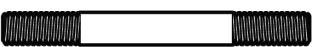

Stainless Steel M4x40 Anti-Wrap Bar x 2
#BRLC7064C

7

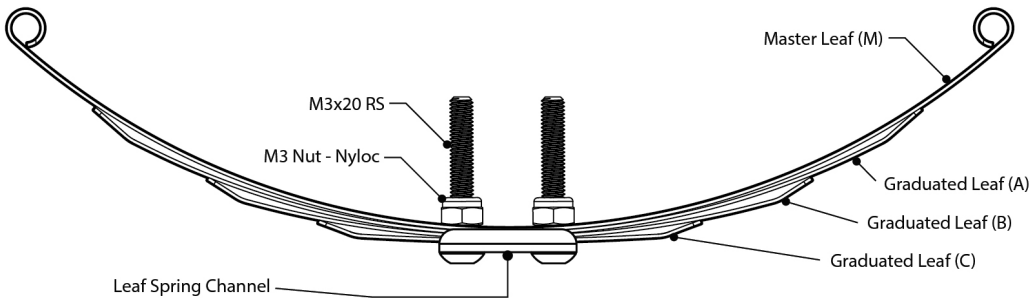

Master Leaf (M)

Graduated Leaf (A)

Graduated Leaf (B)

Graduated Leaf (C)

M3x20 RS

M3 Nut - Nyloc

Leaf Spring Channel

#BRLC7064A

8

#BRX020064B

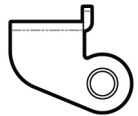

Front Leaf Retainer - Left x 1

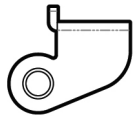

Front Leaf Retainer - Right x 1

9

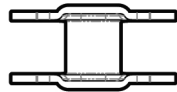

Front Shackle x 2
#BRX020064A

10

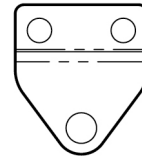

Rear Leaf Retainer - Outside x 2

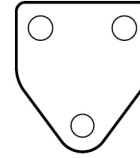

Rear Leaf Retainer - Inside x 2

#BRLC7064F

11

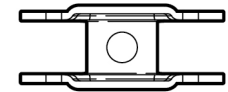

Rear Shackle x 2
#BRLC7064D

12

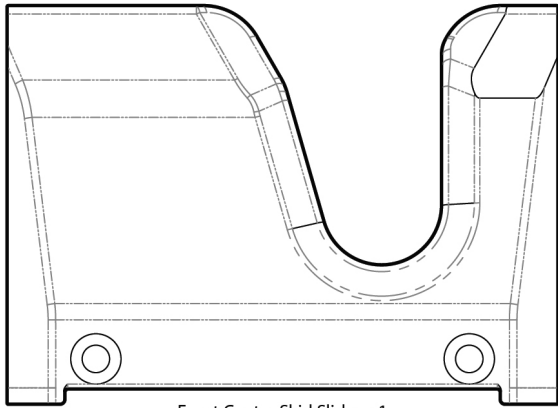

Front Center Skid Slider x 1
#BRX020072F

13

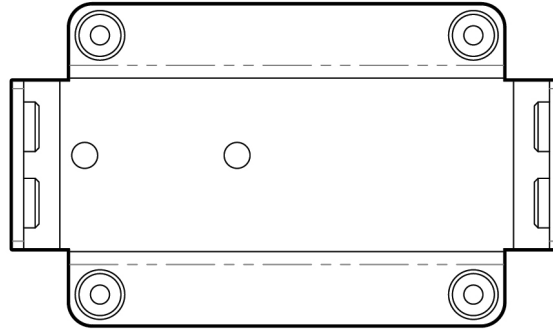

Center Skid Plate x 1
#BRX020020LF

14

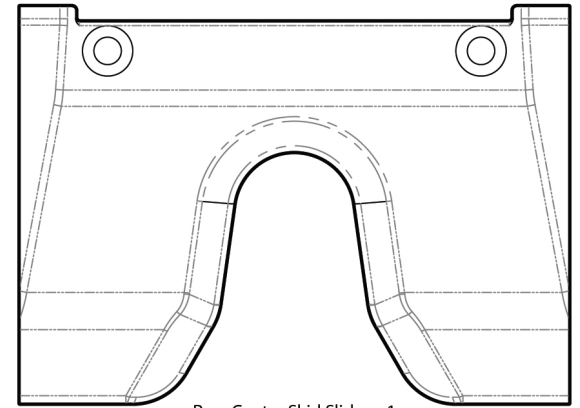

Rear Center Skid Slider x 1
#BRX020072R

13



KUDU™ Nylon Rod End (Straight 18.5mm) x 6
#BRW750306A



KUDU™ Nylon Rod End (Straight 21.8mm) x 2
#BRW750309B



BADASS™ Stainless Steel Pivot Ball x 8
#BRW750300

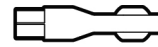

D2 Ball & Rod End x 1
#BRQ90351

15 **B LEAFS / SHOCKS**



M3x24 RS x 3
#BRASBH3024



M3x16 RS x 8
#BRASBH3016



M3x12 RS x 1
#BRASBH3012



M3x10 RS x 1
#BRASBH3010



M4x16 SS x 2
#BRASST4016

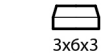

3x6x3 Tapper Spacer x 7
#BRLC7041



D4x7x1 Nylon Spacer x 2
#BRASSPD471/N



D6x1.5 O-Ring x 2
#BRSORD6-15



M3 Nut - Nyloc x 1
#BRASNUTM3

15 **C LEAF SPRINGS**



M3x22 RS x 2
#BRASBH3022



M3x12 RS x 4
#BRASBH3012



M3 Nut - Nyloc x 20
#BRASNUTM3



M2.5 Nut x 2
#BRASNUTM25



M3x8 RS x 2
#BRASBH3008



M2.5x14 RS x 2
#BRASBH2514



D6x1.5 O-Ring x 8
#BRSORD6-15



3x6x3 Tapper Spacer x 2
#BRLC7041

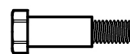

M3x14 Bolt x 12
#BRLC7064E



D4x7x1 Nylon Spacer x 4
#BRASSPD471/N

15 **A CHASSIS**



M3x14 RS x 4
#BRASBH3014



M3x12 RS x 6
#BRASBH3012



M3x10 RS x 11
#BRASBH3010

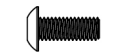

M3x8 RS x 8
#BRASBH3008



M2.5x4 RS x 8
#BRASBH2504

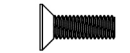

M3x10 CSS x 24
#BRASFH3010

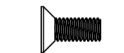

M3x8 CSS x 2
#BRASFH3008

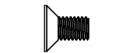

M3x6 RS x 4
#BRASFH3006



M2x4 SC x 4
#BRASCH2004



M3x6 SS x 2
#BRASST3006



M3x3 SS x 4
#BRASST3003



M3 Nut - Nyloc x 2
#BRASNUTM3



M3x5 Hex Cap Screw x 2
#BRASHS3005



Bumper Light Retainer x 2
#BRX020032

15 **D WHEELS**



M4 Nuts - Nyloc x 4
#BRASNUTM4



D4x7x3 Aluminum Spacer x 4
#BRASSP473



D2x10 Pin x 4
#BRASPIN210

PART LOCATION MAP (MIDDLE)



16

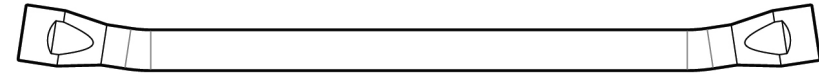

Stainless Steel Tie Rod x 1
#BRD9022A

17



Fine Tunable Link - 55mm x 1
#BRLC7050

18

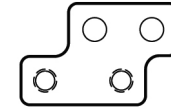

Steering Servo Mount x 2
#BRX020007

19



Body Latch Pin x 4
#BRX020034

20

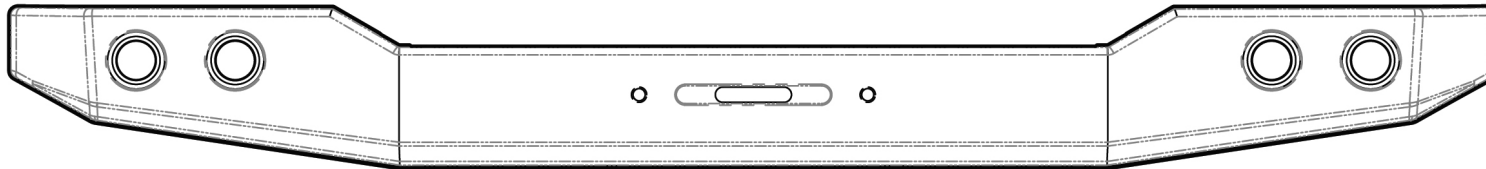

Front Bumper x 1
#BRX020015F

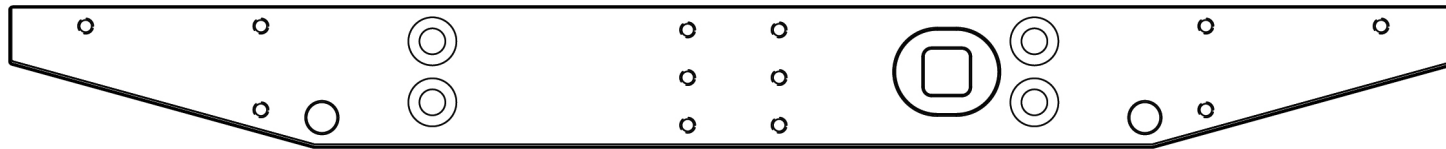

Rear Bumper x 1
#BRX020015R

21

#BRX020018F

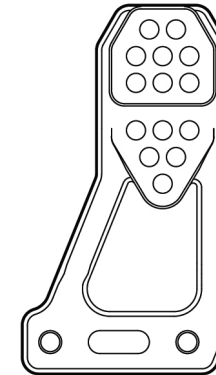

Front Shock Mount - Left x 1

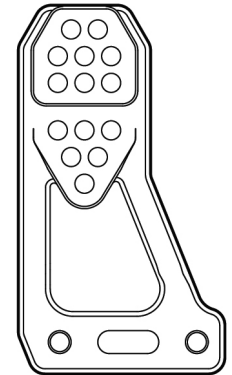

Front Shock Mount - Right x 1

22

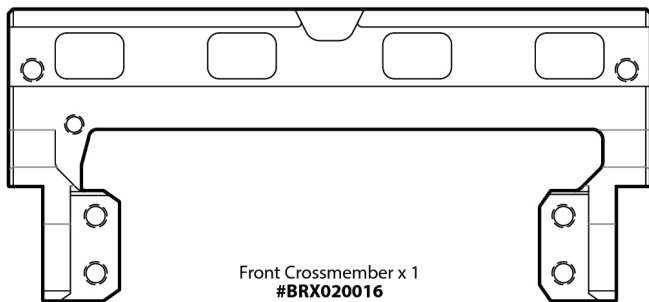

Front Crossmember x 1
#BRX020016

23

#BRLC7019

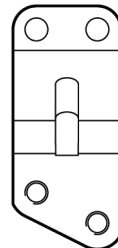

Side Gearbox Mount
- Left x 1

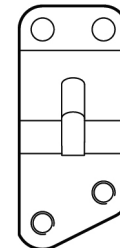

Side Gearbox Mount
- Right x 1

24

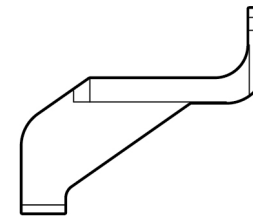

Rear Gearbox Mount x 1
#BRX020017

25

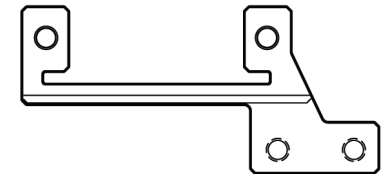

Mini Servo Mount x 1
#BRX020009

26

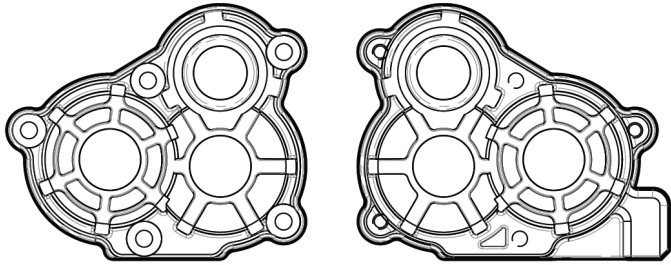

SRD™ Transfer Case Housing x 1
#BRX020047

27

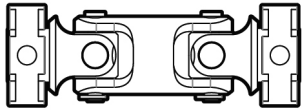

Steel Connection Drive Shaft (33mm) x 1
#BRX020028

30



Shift Rod x 1
#BRX020051

31



Quick Release Body Mount - Right x 1



Quick Release Body Mount - Left x 1

#BRX020062

34

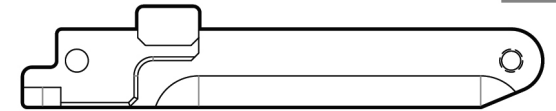

Quick Release Body Mount Extension - Right x 1

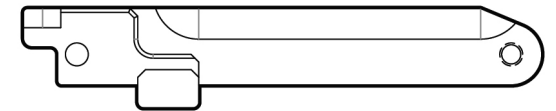

Quick Release Body Mount Extension - Left x 1

#BRX020063

32

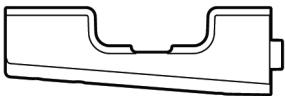

Body Post x 4
#BRX020039

33

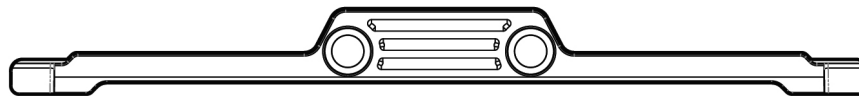

Quick Release Body Latch x 2
#BRX020061

35



Mid Crossmember x 1
#BRX020014

28

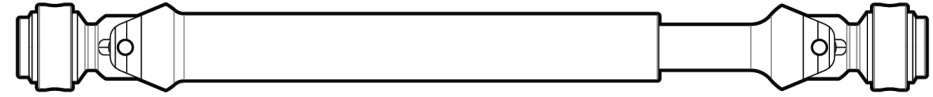

KUDU™ HD CVD Center Drive Shaft x 2
#BRX020043

29

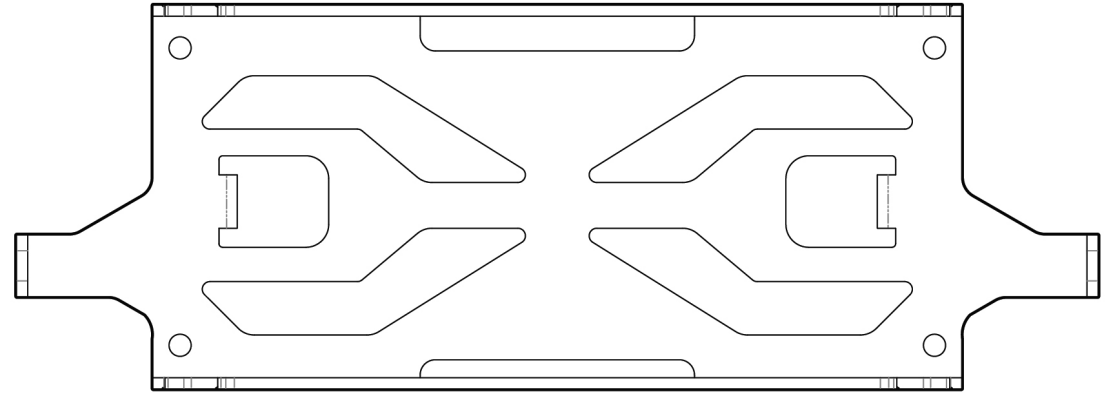

Battery Tray x 1
#BRX020021

36

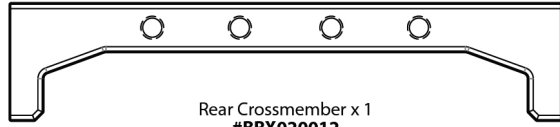

Rear Crossmember x 1
#BRX020012

38

#BRX020018R

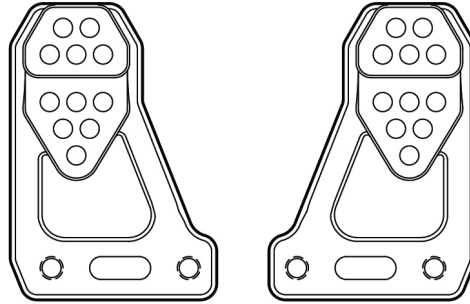

Rear Shock Mount - Left x 1
Rear Shock Mount - Right x 1

39

#BRX020019

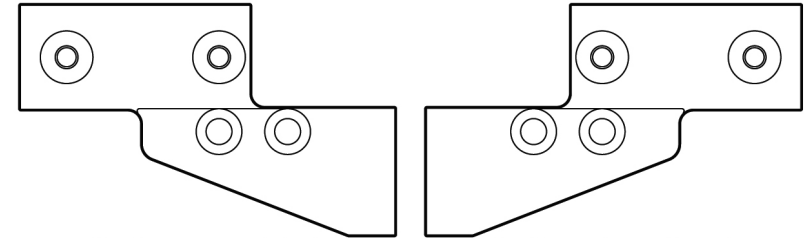

Rear Bumper Mount - Left x 1
Rear Bumper Mount - Right x 1

37

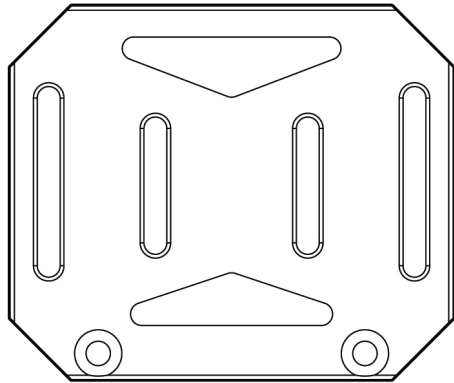

ESC Mounting Plate x 1
#BRX020079

40

#BRLC7033

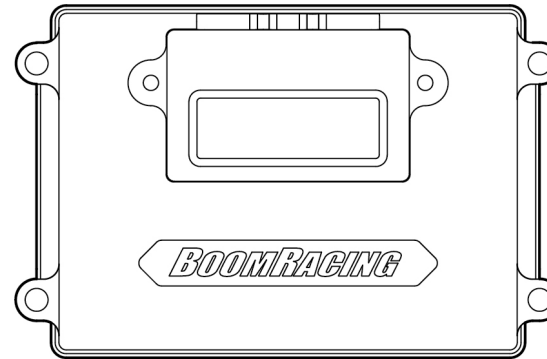

Receiver Box Lid x 1



Stainless Steel Sealing Plate x 1

#BRLC7033A

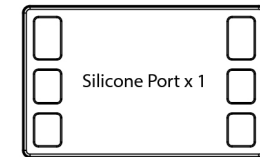

Silicone Port x 1

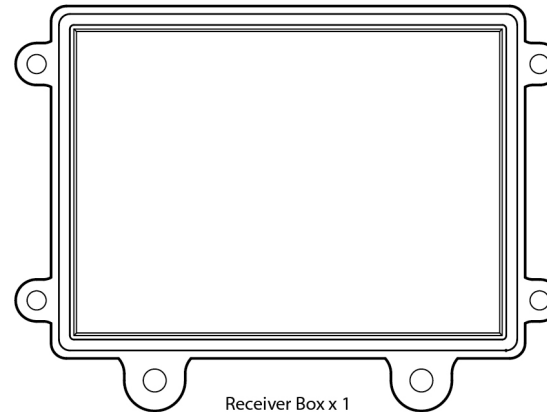

Receiver Box x 1

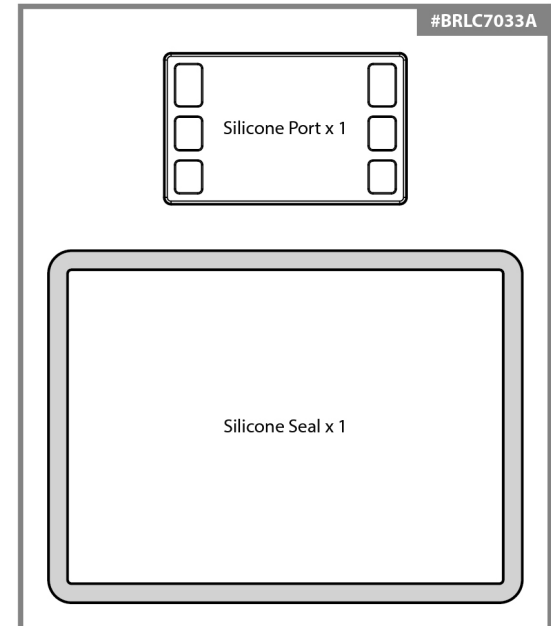

Silicone Seal x 1

PART LOCATION MAP (BOTTOM)

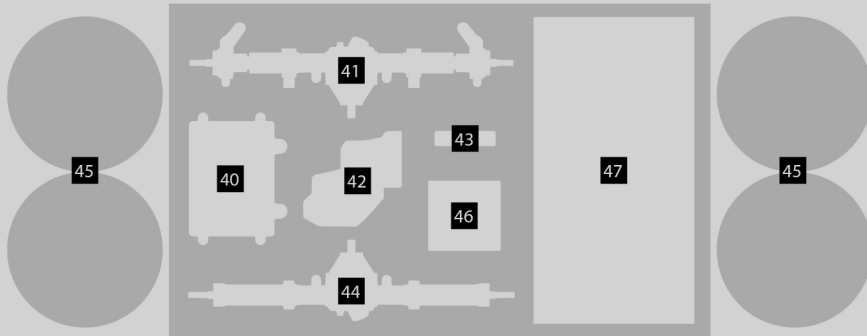

41

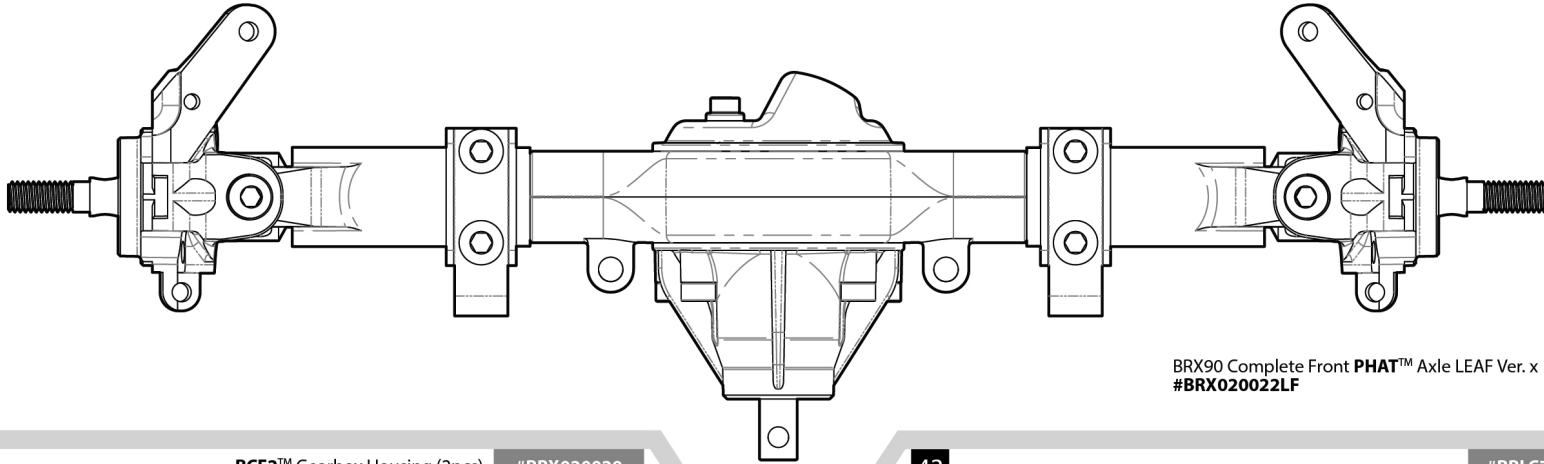

BRX90 Complete Front **PHAT™** Axle LEAF Ver. x 1
#BRX020022LF

42

BCF2™ Gearbox Housing (2pcs)

#BRX020029

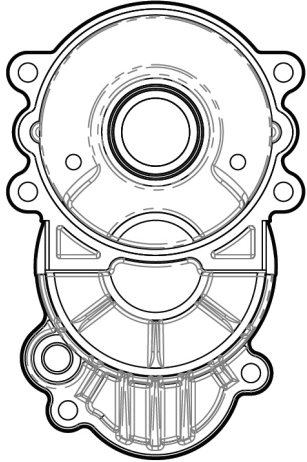

Gearbox Housing A

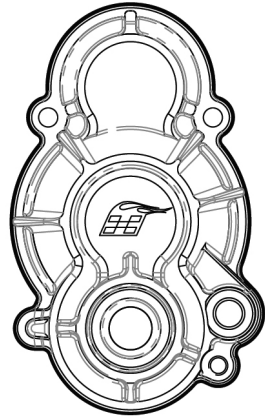

Gearbox Housing B

43

#BRLC7027

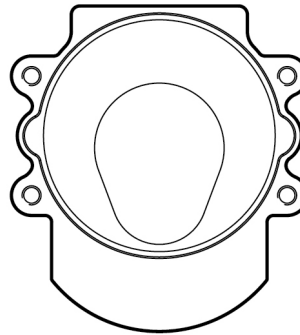

Gearbox Adapter x 1

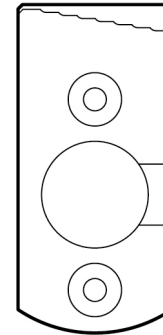

Motor Mount x 1

44

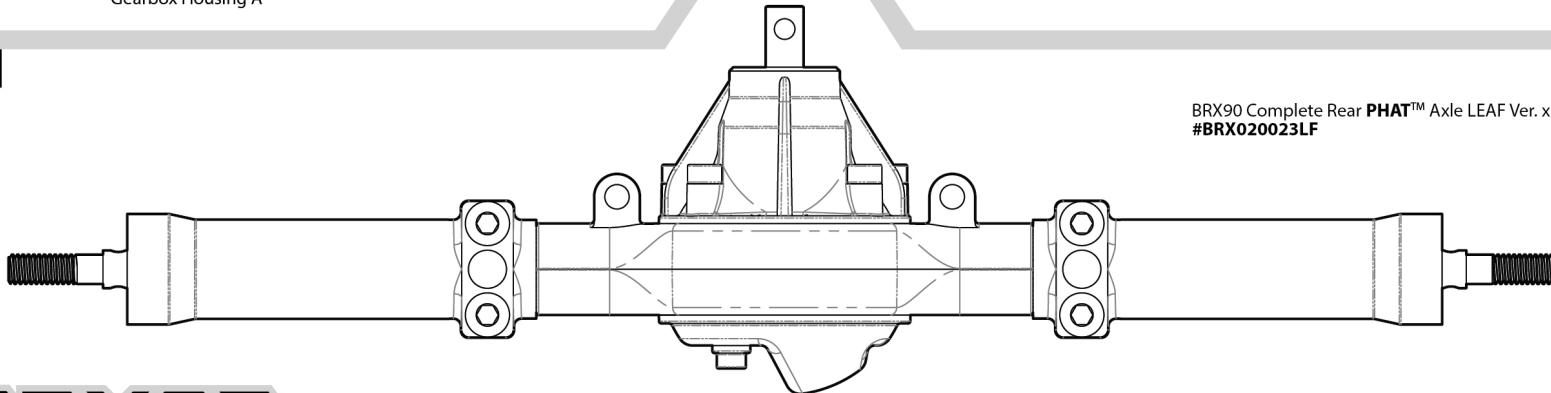

BRX90 Complete Rear **PHAT™** Axle LEAF Ver. x 1
#BRX020023LF

45

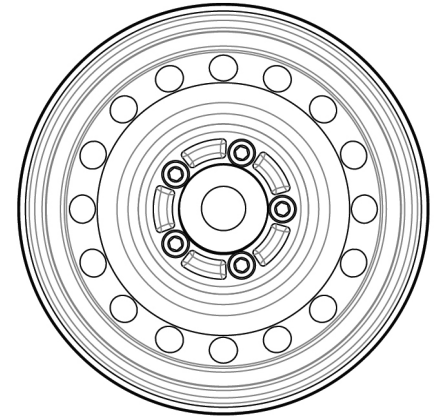

1.9" Narrow 16-Hole Classic Steelie
Reversible Beadlock Wheels (Gun Metal) x 4
#BRW780920GM
with XT500 (#BRXT500V2) Wheel Hub



5100 Scale Center Wheel Hub Cap x 4
#BRW780923

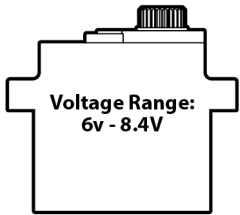

JX Waterproof HV Mini Servo x 1
#JX/PDI-HV1151MG

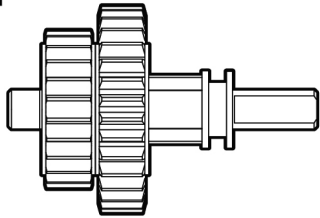

2-Speed Gear Unit x 1
#BRLC7044E

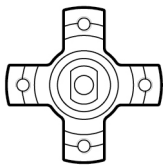

Spur Gear Mount x 1
#BRLC7030

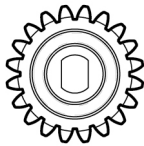

Spur Gear 20T x 2
#BRLC7029-20T

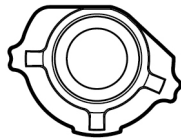

Bearing Holder x 1
#BRX020029A

47 **E** GEARBOX / TRANSFER CASE

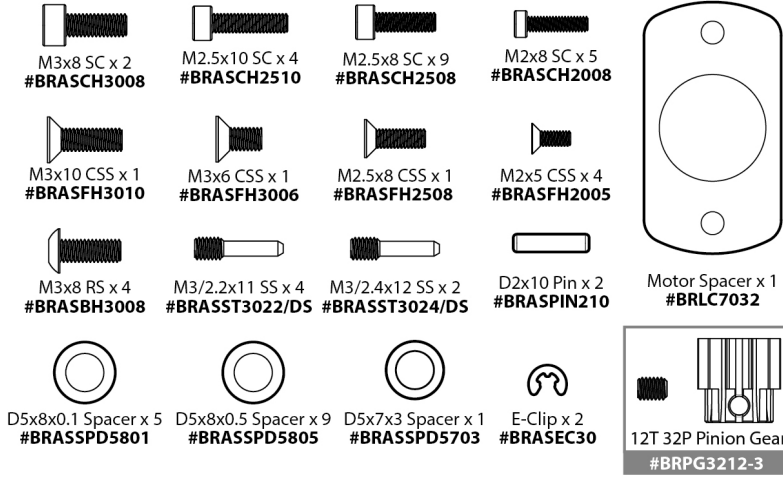

47 **F** RECEIVER BOX

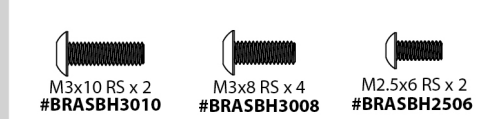

47 **G** BODY MOUNTS

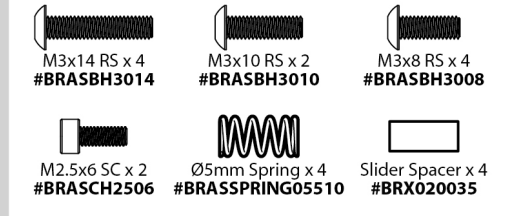

47 **H** SERVOS

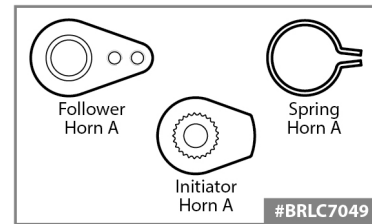

47 **I** GEARS, SHAFTS & BEARINGS - TRANSFER CASE

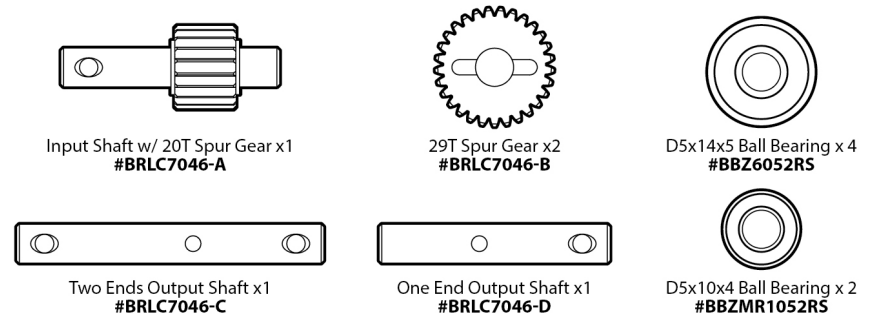

47 **J** GEARS, SHAFTS & BEARINGS - GEAR BOX

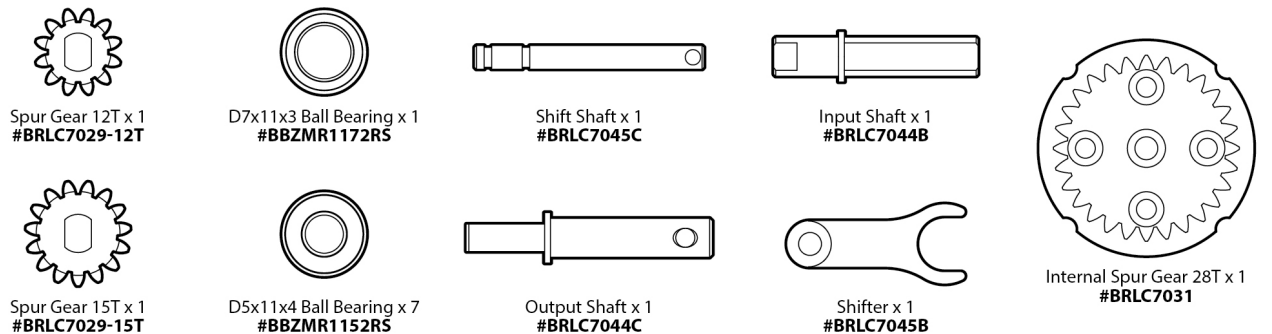

47



Extension Cable x 2
#BRLC7095

47

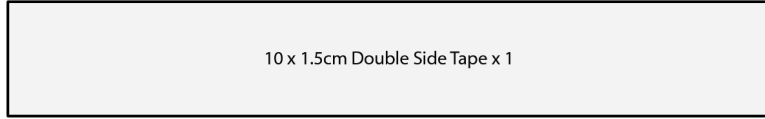

10 x 1.5cm Double Side Tape x 1



47

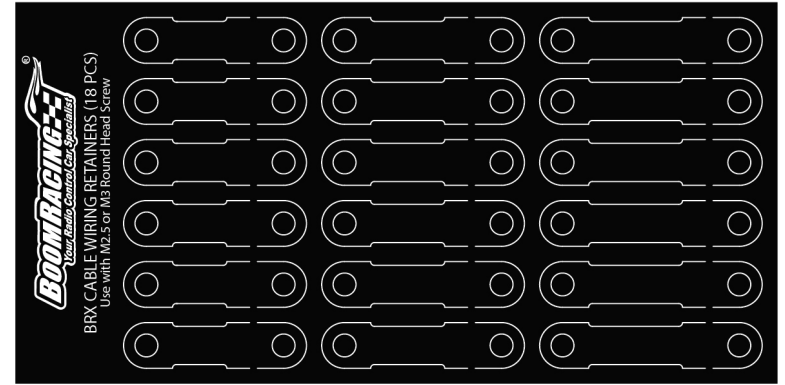

Cable Wiring Retainers
#BRT10037

47

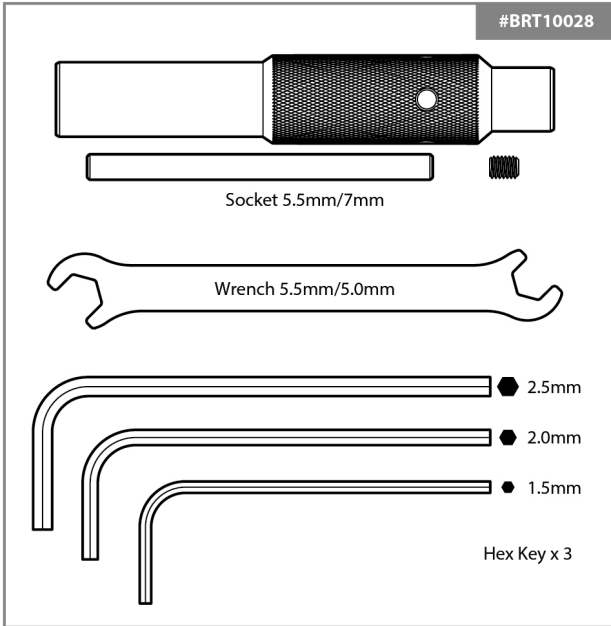

#BRT10028

Socket 5.5mm/7mm

Wrench 5.5mm/5.0mm

2.5mm

2.0mm

1.5mm

Hex Key x 3

#BRT10053

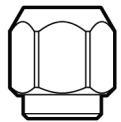

Pivot Ball Tool x 1



M3x18 RS x 1
#BRASBH3018

47

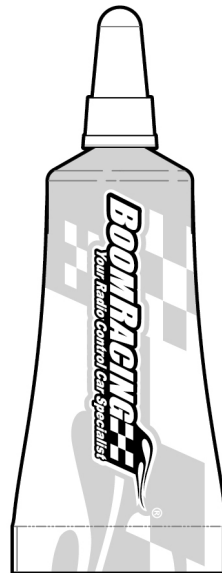

Black Graphite Grease 10g x 1
#BRGRS1055-10

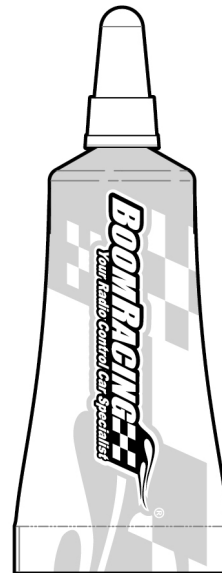

Silicone Grease 10g x 1
#BRGRS10274-10



30WT Shock Oil 15ml x 1
(Available separately in 60ml)
#BRSHK030



242 Thread Lock 2g x 1
(Available separately in 10g)
#BRGRS242



1 - CHASSIS RAIL

Parts Needed:



Body Latch Pin x 4
#BRX020034

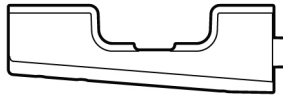

Body Post x 4
#BRX020039

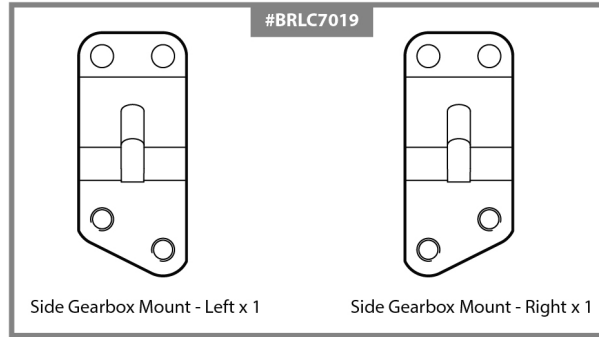

#BRLC7019

Side Gearbox Mount - Left x 1

Side Gearbox Mount - Right x 1

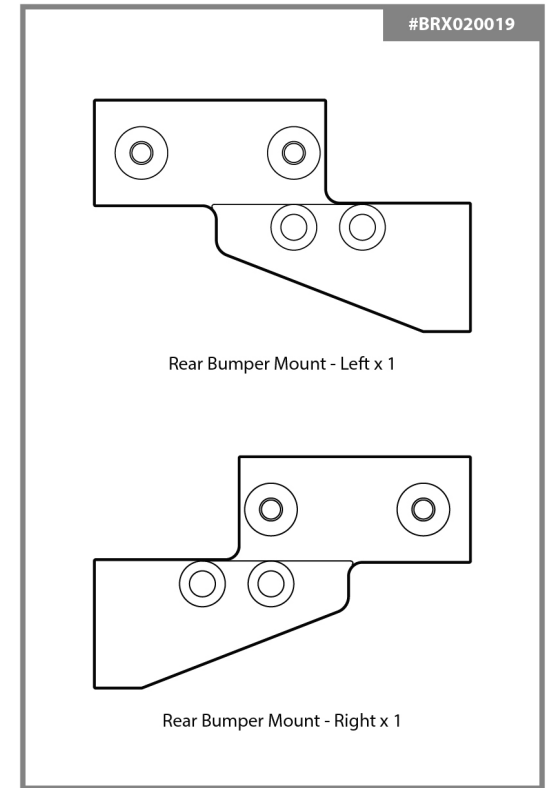

#BRX020019

Rear Bumper Mount - Left x 1

Rear Bumper Mount - Right x 1

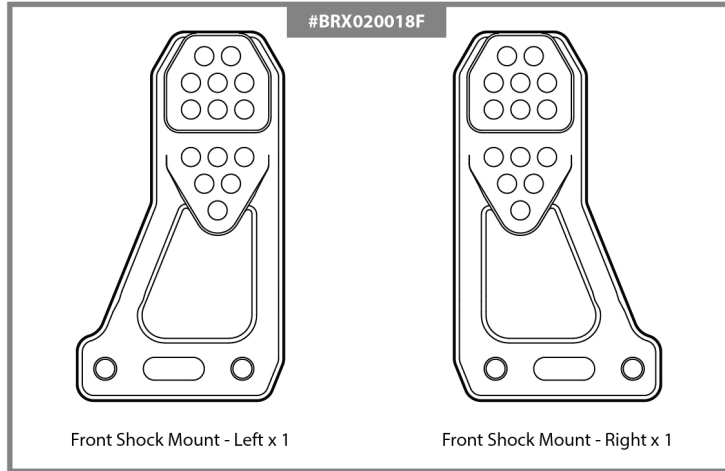

#BRX020018F

Front Shock Mount - Left x 1

Front Shock Mount - Right x 1

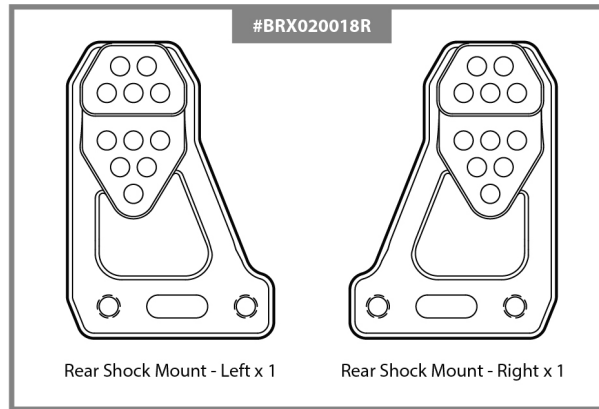

#BRX020018R

Rear Shock Mount - Left x 1

Rear Shock Mount - Right x 1

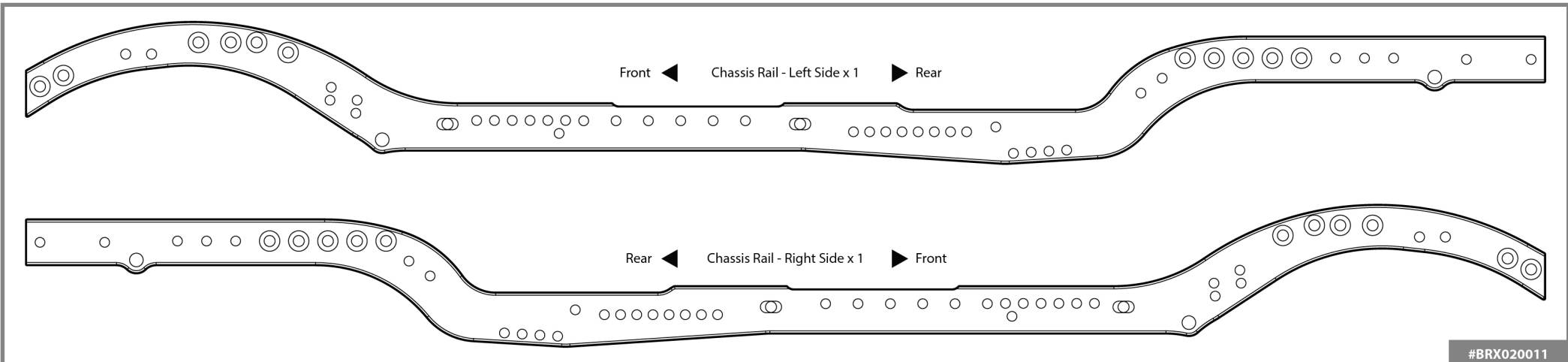

Front ◀ Chassis Rail - Left Side x 1 ▶ Rear





Rear ◀ Chassis Rail - Right Side x 1 ▶ Front

#BRX020011

CHASSIS RAIL

CHASSIS RAIL

A CHASSIS

-  M3x10 RS x 4
#BRASBH3010
-  M3x8 RS x 4
#BRASBH3008
-  M3x10 CSS x 12
#BRASFH3010
-  M3x3 SS x 4
#BRASST3003



Apply Thread Lock to all screws.
(Do Not Use Red Loctite)

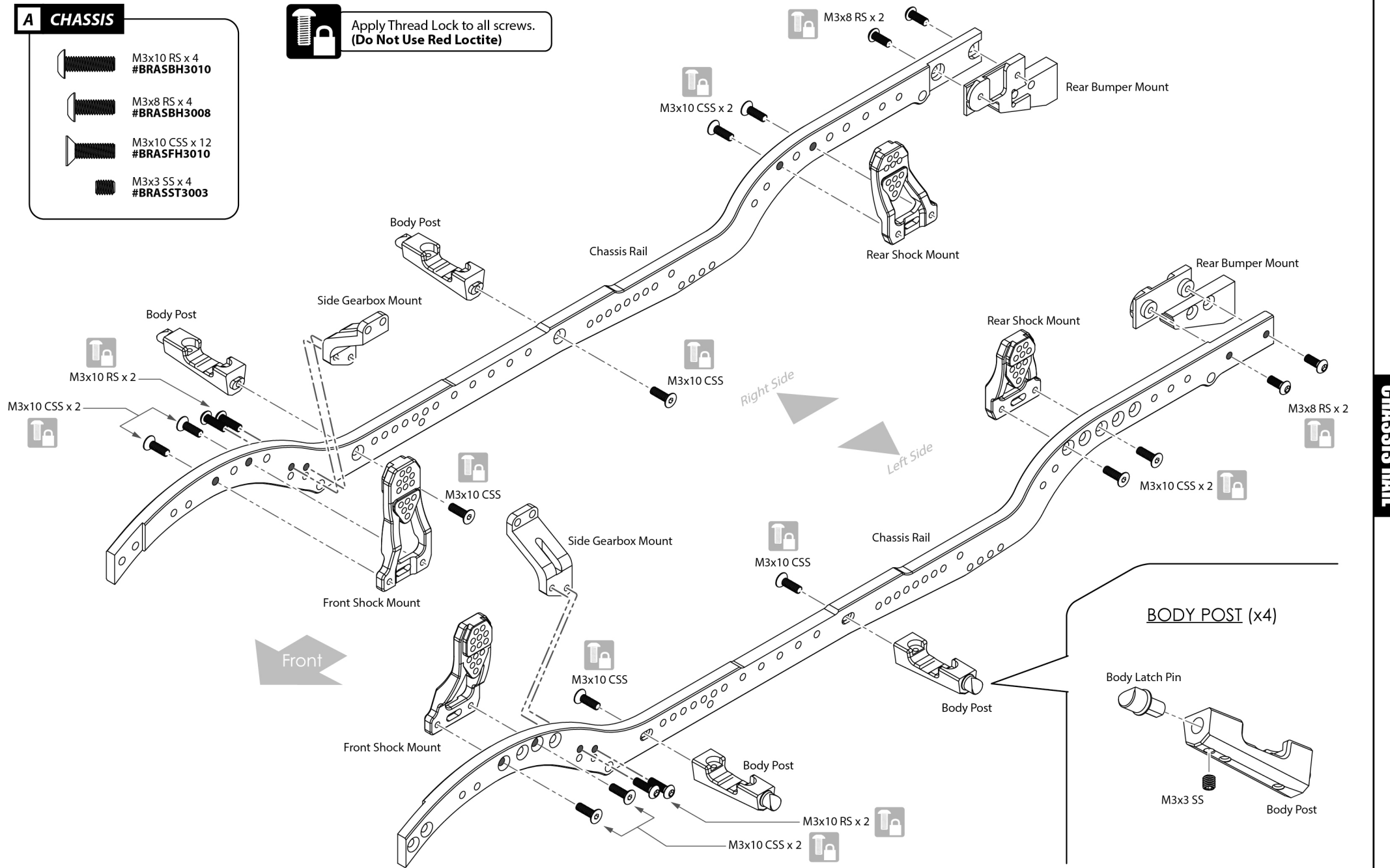

CHASSIS RAIL

CHASSIS RAIL

BRX02



2 - CHASSIS

Parts Needed:

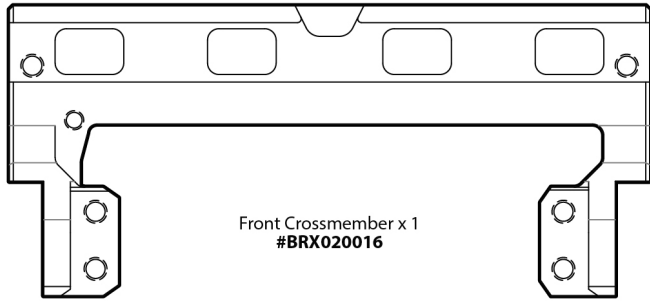

Front Crossmember x 1
#BRX020016

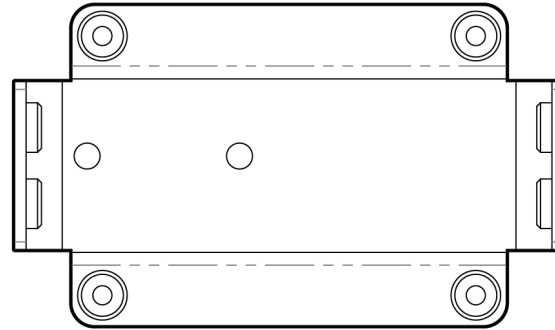

Center Skid Plate x 1
#BRX020020LF

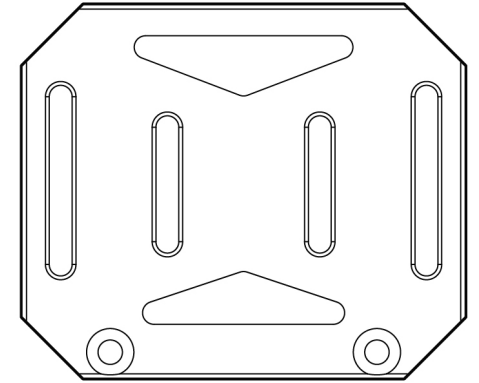

ESC Mounting Plate x 1
#BRX020079



Mid Crossmember x 1
#BRX020014

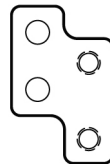

Steering Servo Mount x 2
#BRX020007

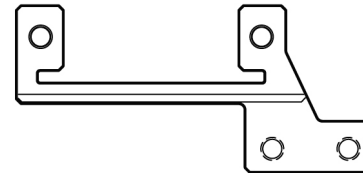

Mini servo Mount x 1
#BRX020009

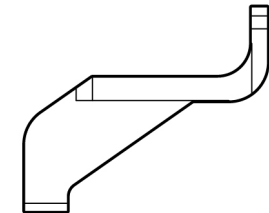

Rear Gearbox Mount x 1
#BRX020017

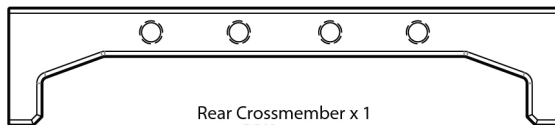

Rear Crossmember x 1
#BRX020012

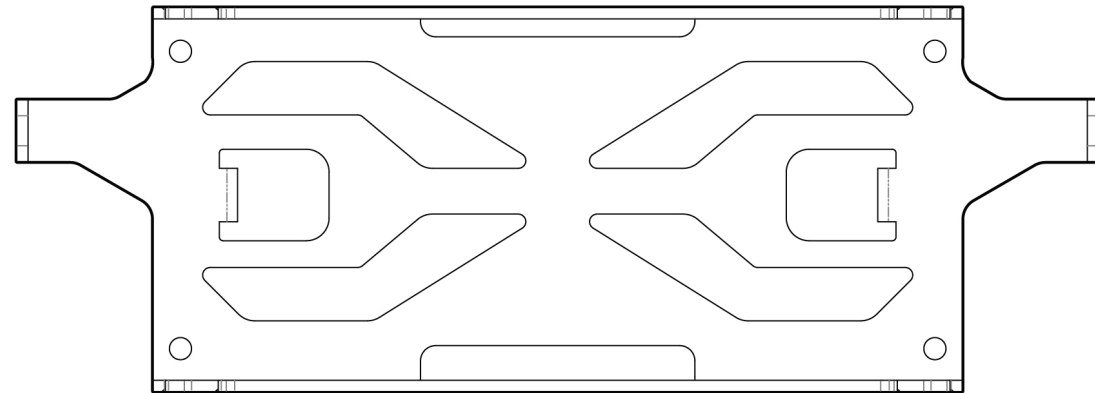

Battery Tray x 1
#BRX020021

A CHASSIS

- M3x12 RS x 4
#BRASBH3012
- M3x10 RS x 4
#BRASBH3010
- M3x10 CSS x 8
#BRASFH3010

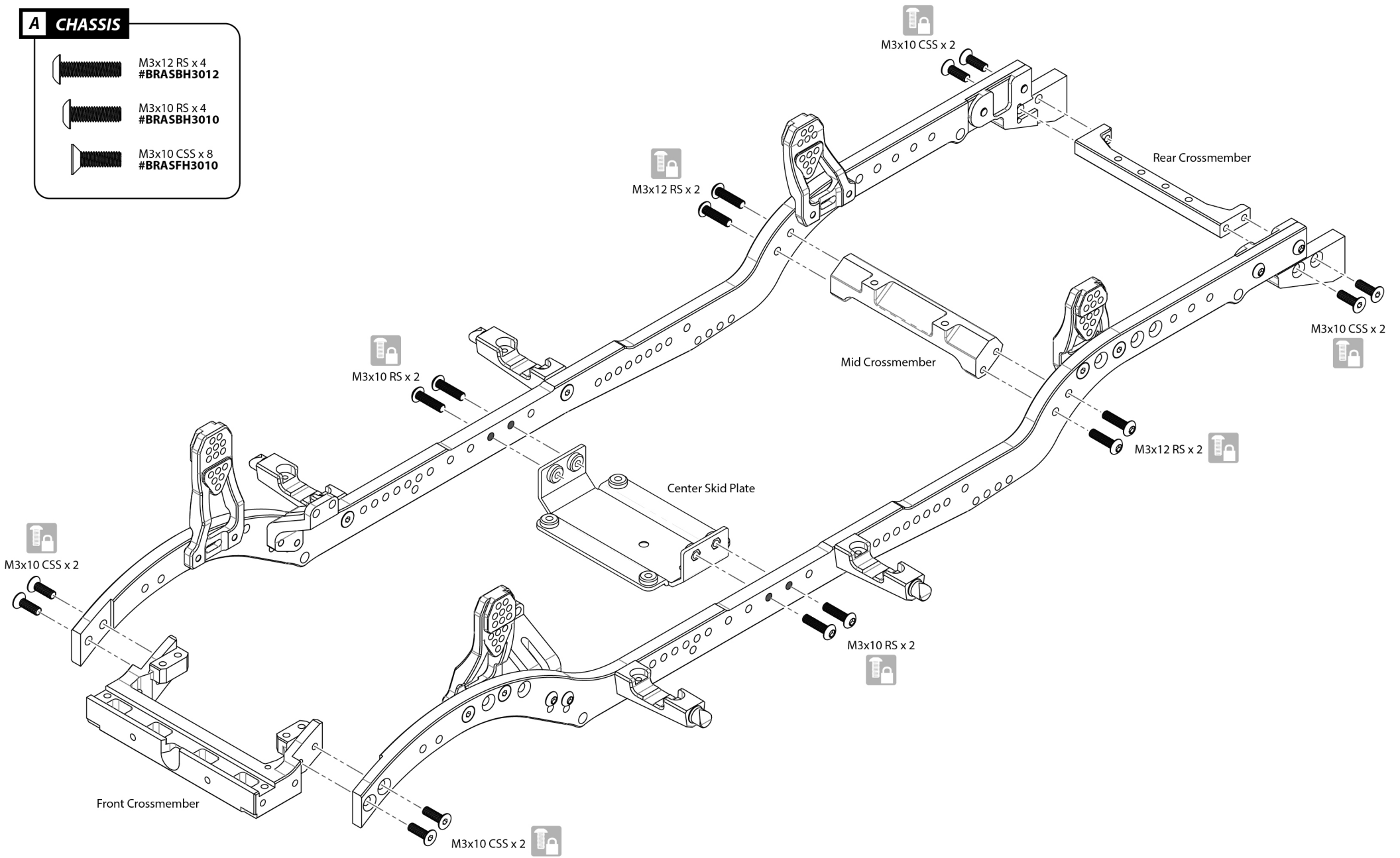



CHASSIS

CHASSIS

BRX02



A CHASSIS

-  M3x10 RS x 2
#BRASBH3010
-  M3x8 RS x 4
#BRASBH3008
-  M3x8 CSS x 2
#BRASFH3008

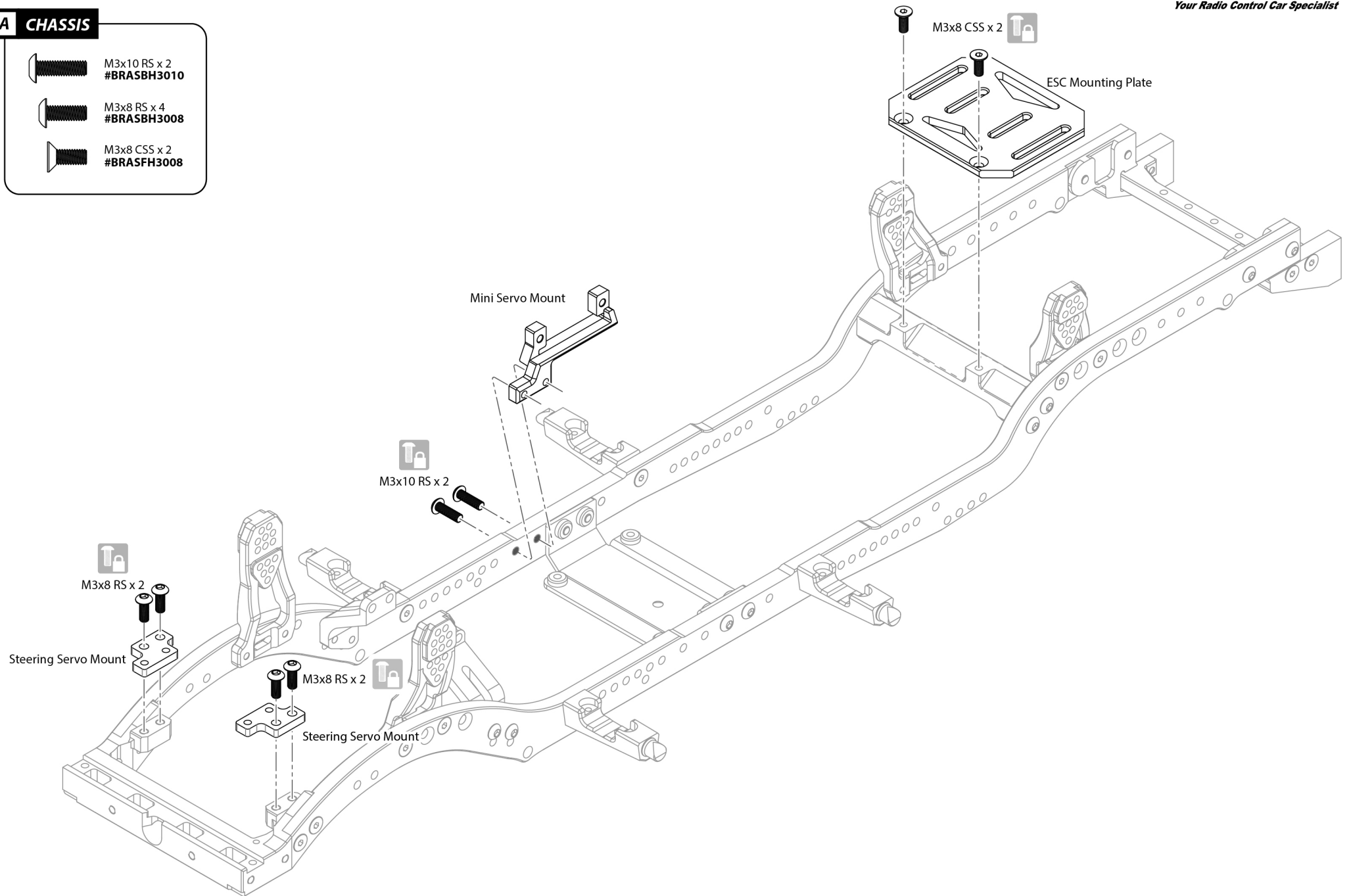

CHASSIS

CHASSIS

A CHASSIS



M3x12 RS x 2
#BRASBH3012



M3x10 RS x 1
#BRASBH3010



M3 Nut - Nyloc x 2
#BRASNUTM3

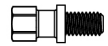

M3x5 Hex Cap Screw x 2
#BRASH53005

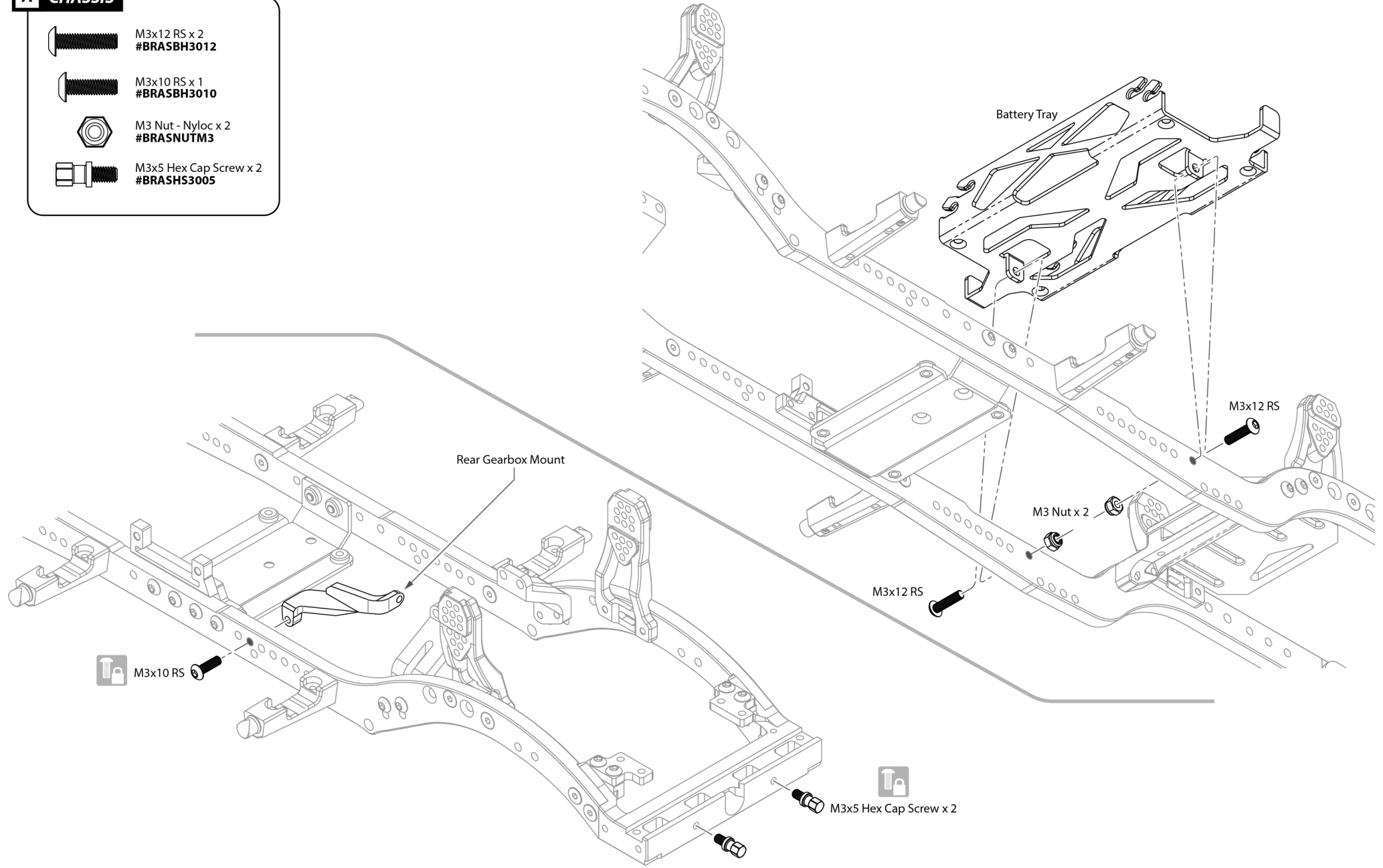

CHASSIS

CHASSIS

3 - BUMPERS

Parts Needed:

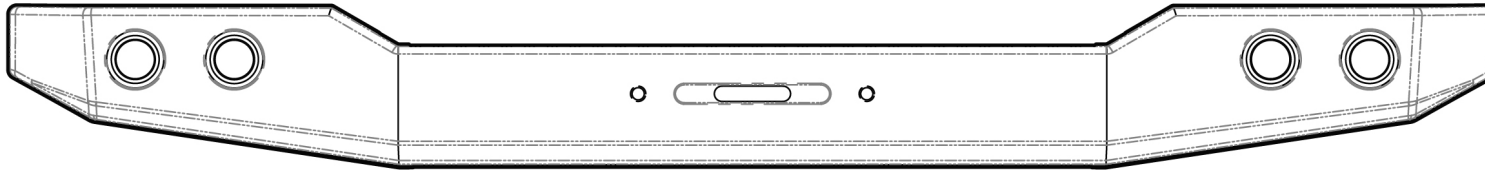

Front Bumper x 1
#BRX020015F

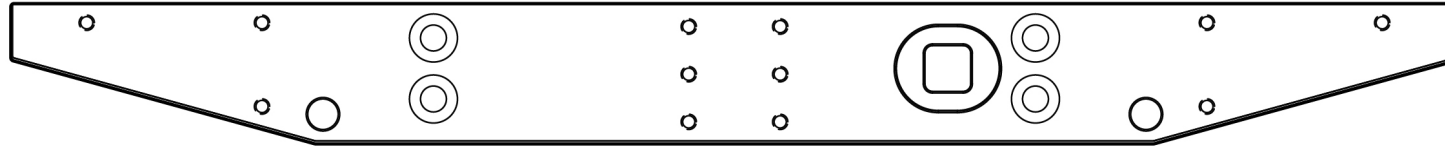

Rear Bumper x 1
#BRX020015R

A CHASSIS

-  M3x10 CSS x 4
#BRASFH3010
-  M3x6 SS x 2
#BRASST3006

FRONT BUMPER

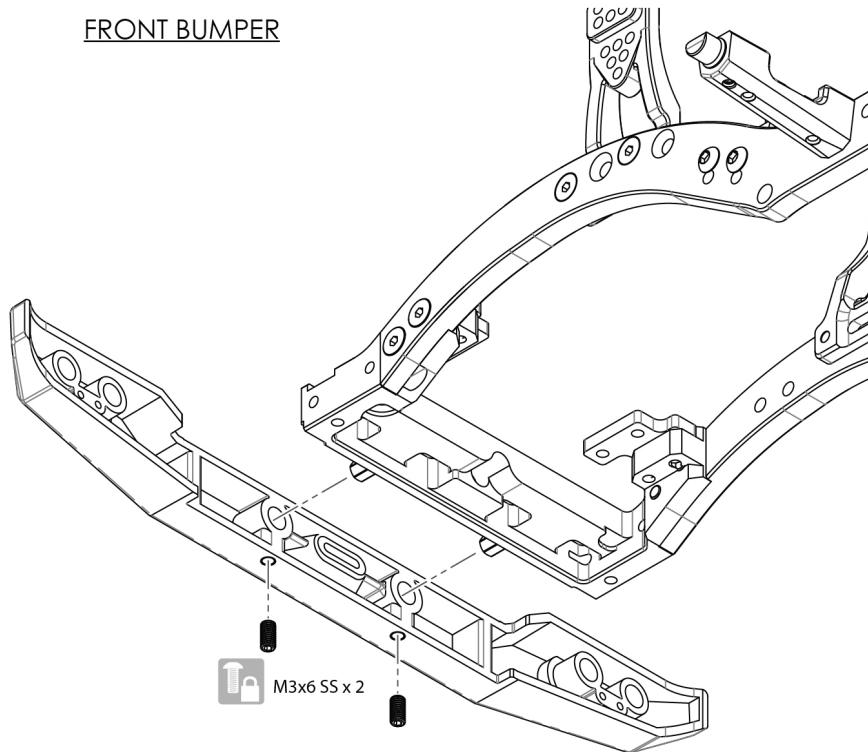

REAR BUMPER

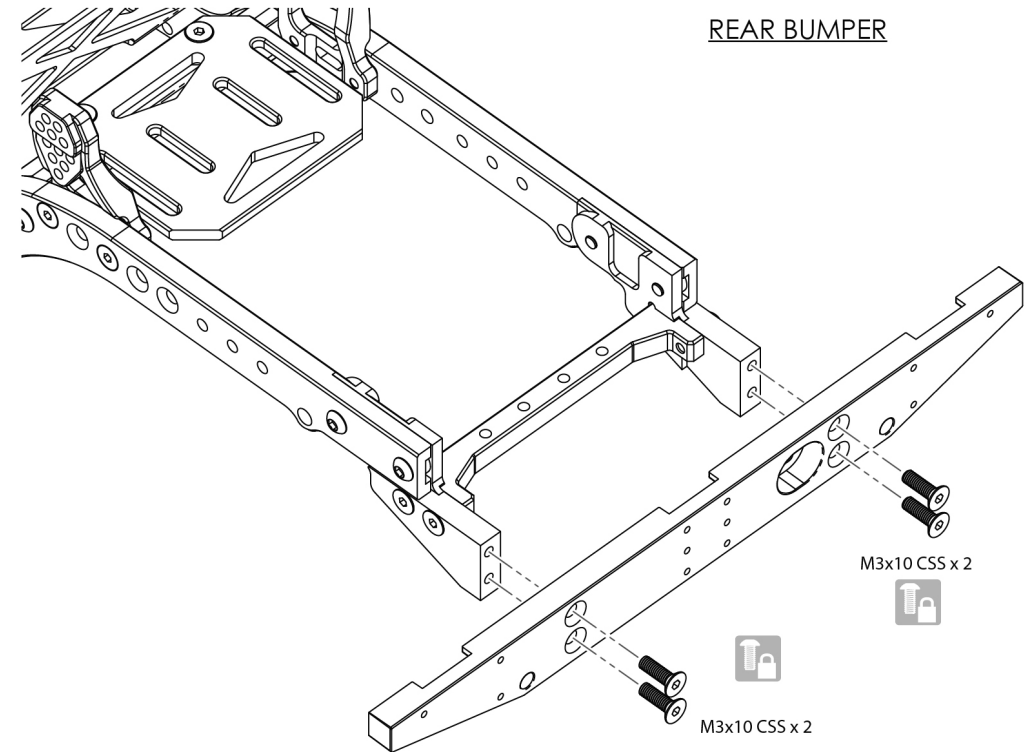

BUMPERS

BUMPERS

4 - GEARBOX

Parts Needed:

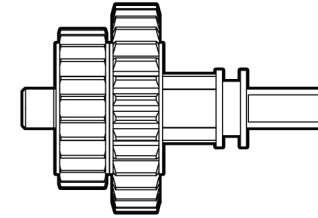
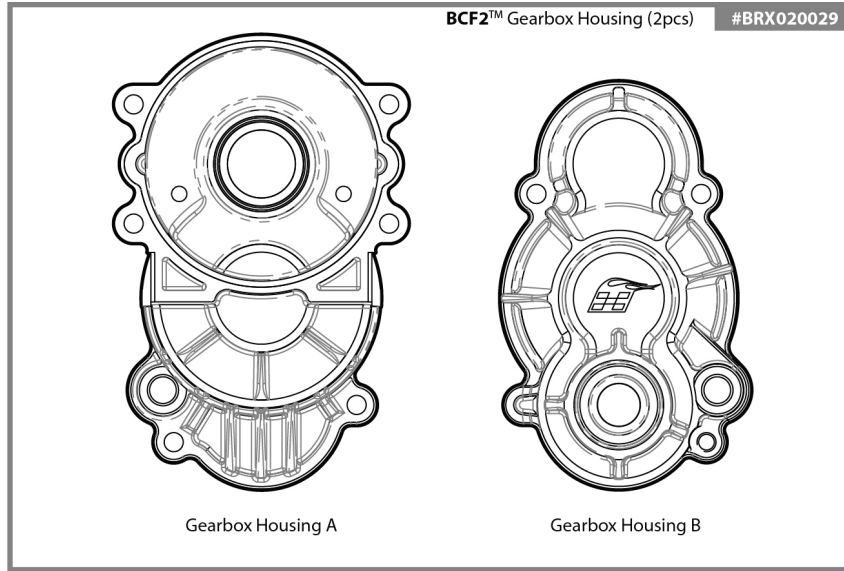

2-Speed Gear Unit x 1
#BRLC7044E

J GEARS, SHAFTS & BEARINGS - GEAR BOX

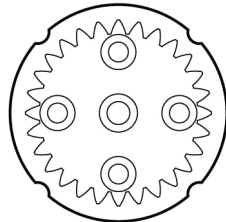

Internal Spur Gear 28T x 1
#BRLC7031

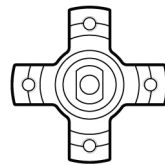

Spur Gear Mount x 1
#BRLC7030



Spur Gear 12T x 1
#BRLC7029-12T

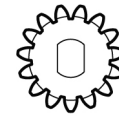

Spur Gear 15T x 1
#BRLC7029-15T

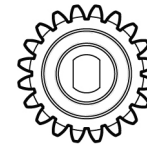

Spur Gear 20T x 2
#BRLC7029-20T



D5x11x4 Ball Bearing x 7
#BBZMR1152RS

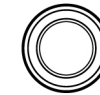

D7x11x3 Ball Bearing x 1
#BBZMR1172RS

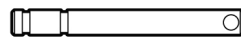

Shift Shaft x 1
#BRLC7045C

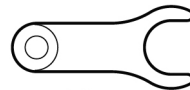

Shifter x 1
#BRLC7045B

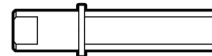

Input Shaft x 1
#BRLC7044B



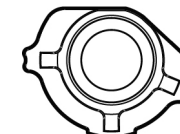

Output Shaft x 1
#BRLC7044C



Bearing Holder x 1
#BRX020029A

4.1

E GEARBOX / TRANSFER CASE

-  M2.5x8 CSS x 1
#BRASFH2508
-  M2x5 CSS x 4
#BRASFH2005

 Fit the Spur Gear Mount onto the Spur Gear by tightening M2x5 countersunk screws.

To install or remove the spur gear from the gearbox, align the spur gear as pictured and temporarily insert two M3 screws** to act as stoppers.

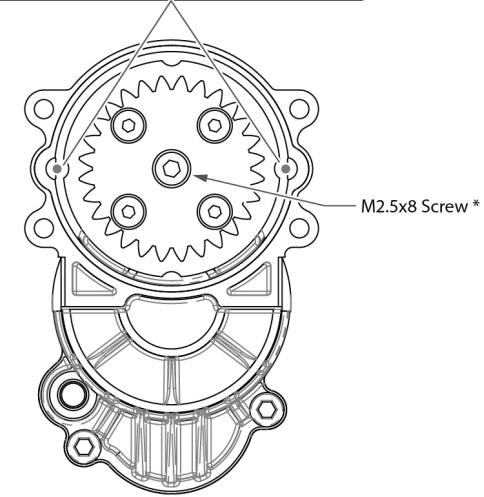
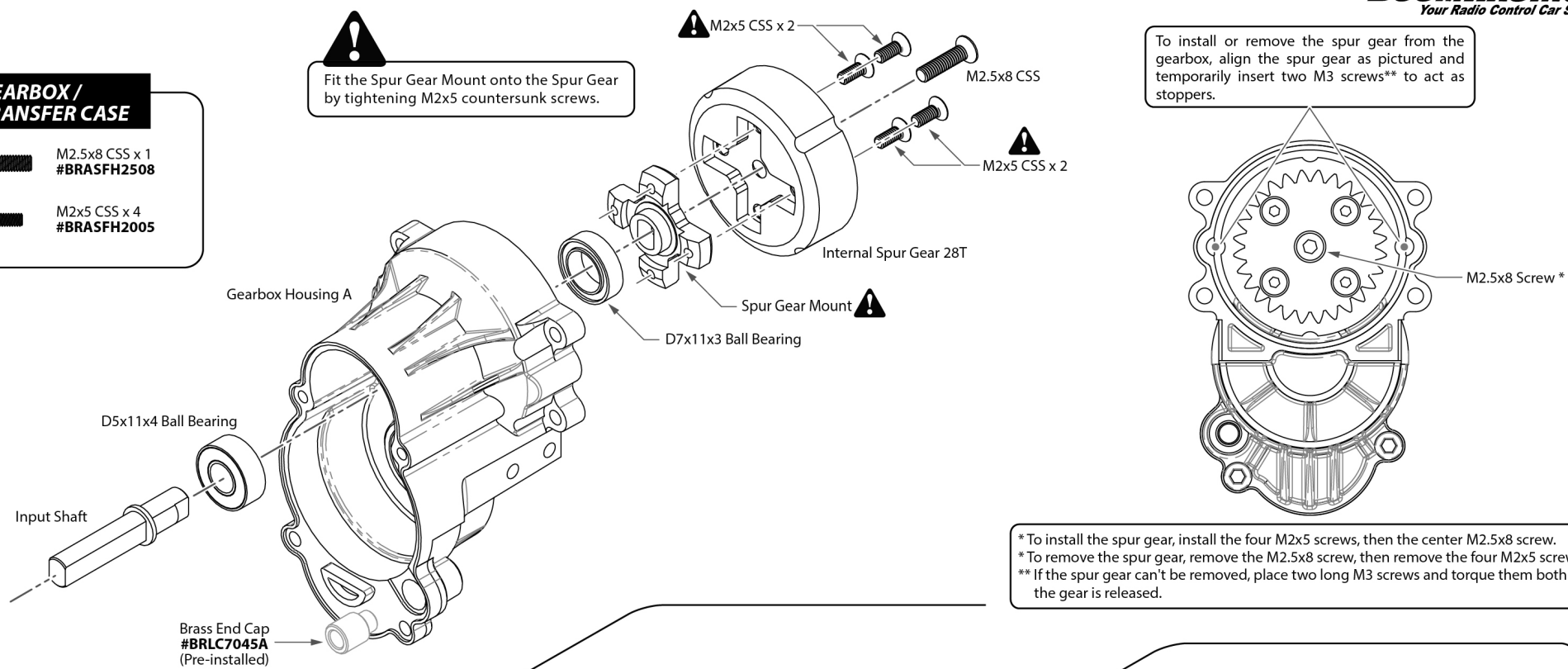

* To install the spur gear, install the four M2x5 screws, then the center M2.5x8 screw.
* To remove the spur gear, remove the M2.5x8 screw, then remove the four M2x5 screws.
** If the spur gear can't be removed, place two long M3 screws and torque them both until the gear is released.

4.2

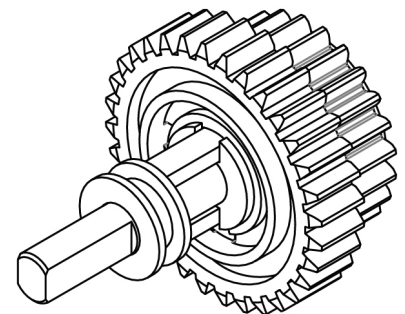

2-Speed Gear Unit

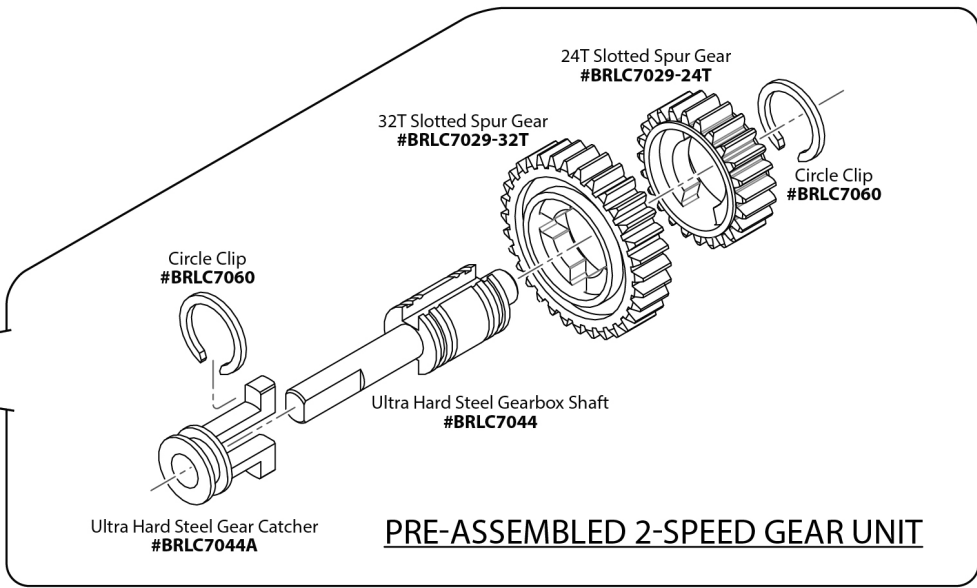

PRE-ASSEMBLED 2-SPEED GEAR UNIT

GEARBOX

GEARBOX

4.3

E GEARBOX / TRANSFER CASE



D5x8x0.5 Spacer x 4
#BRASSPD5805



E-Clip x 2
#BRASEC30



D5x8x0.1 Spacer x 4
#BRASSPD5801

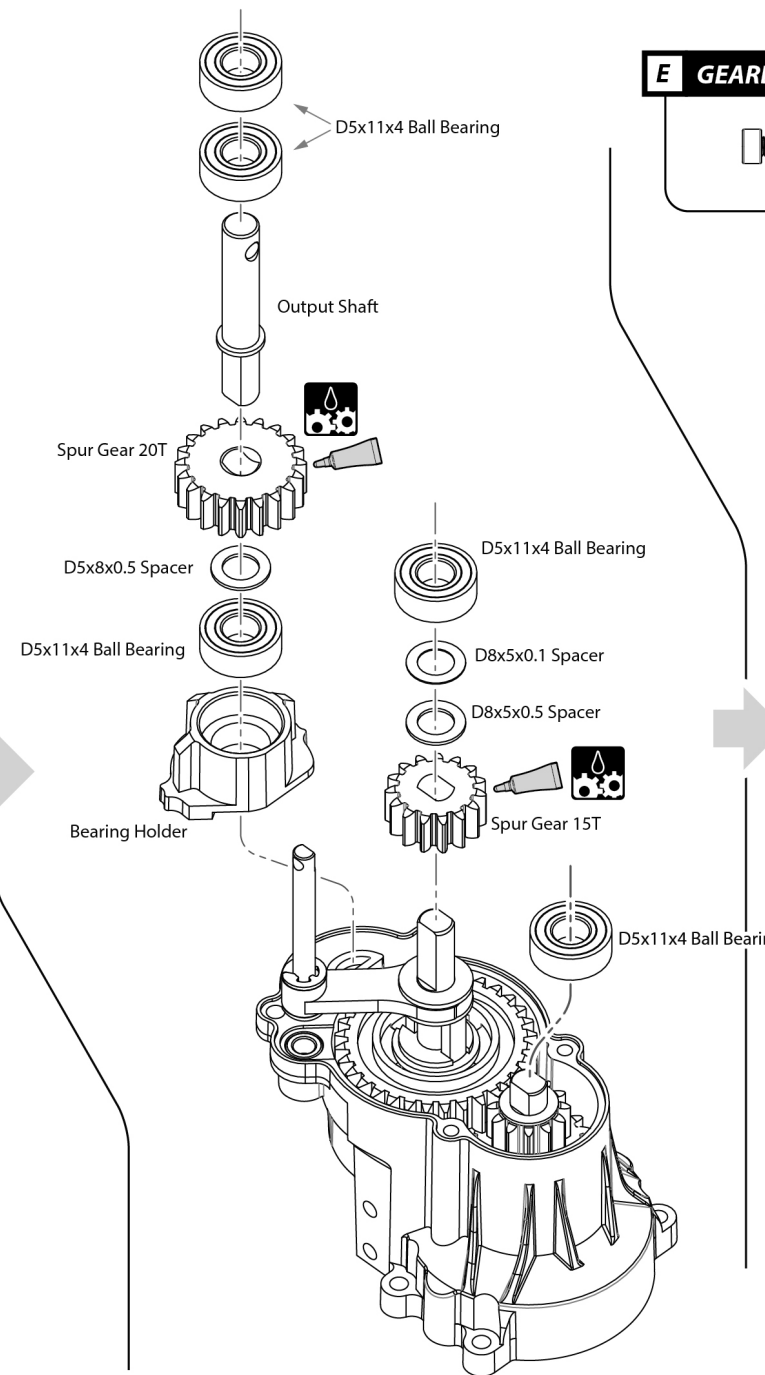
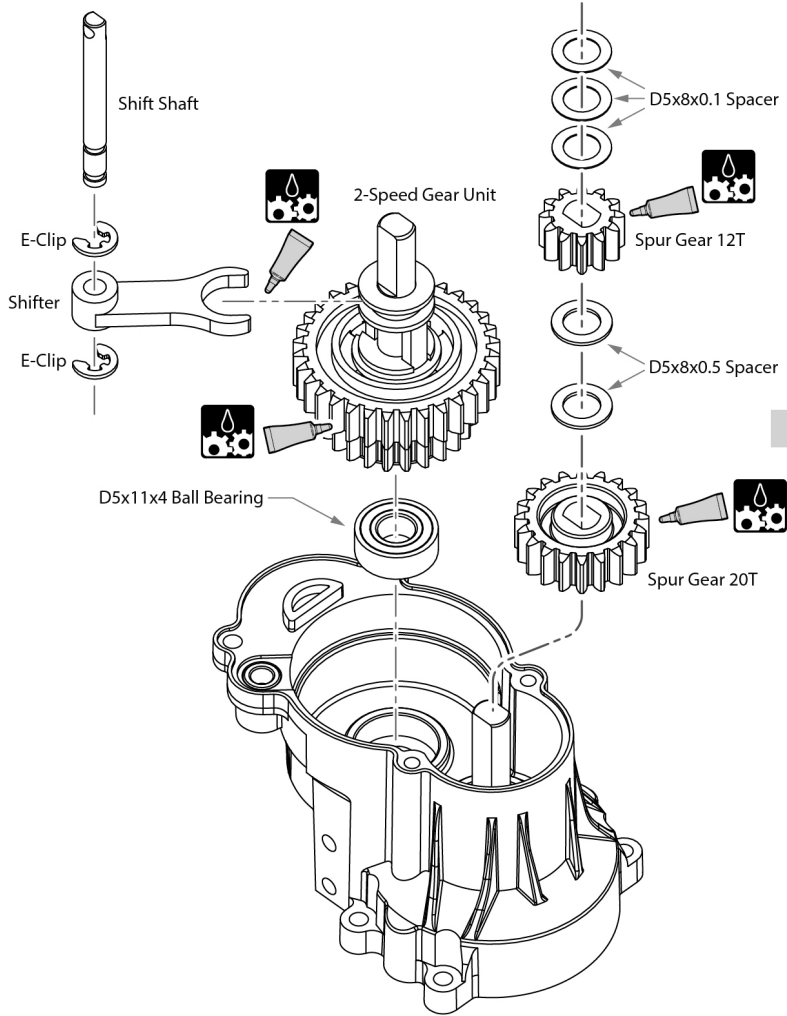

E GEARBOX / TRANSFER CASE



M2.5x10 SC x 4
#BRASCH2510

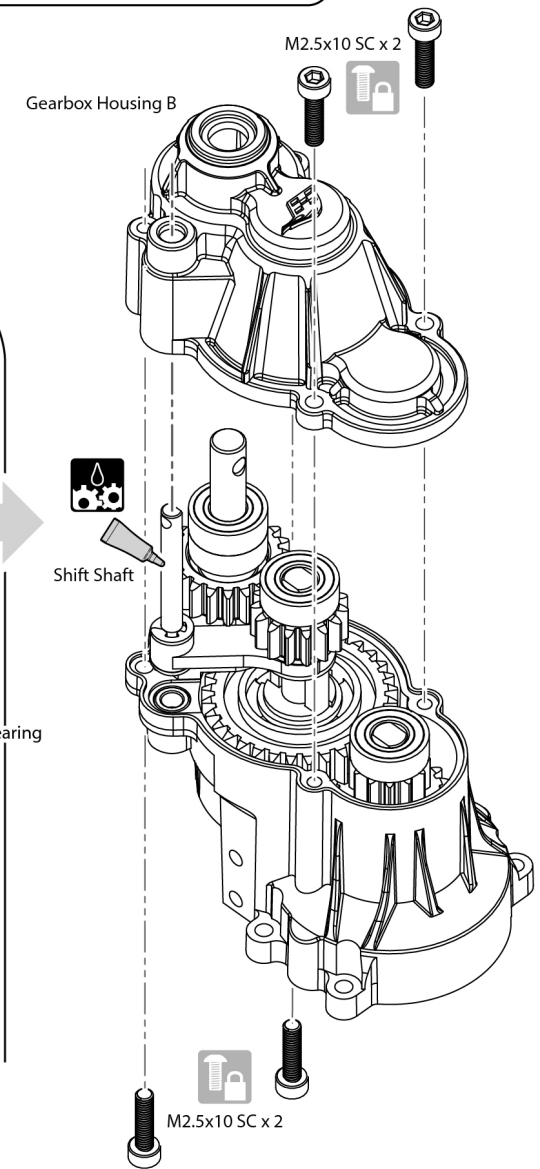

5 - TRANSFER CASE

Parts Needed:

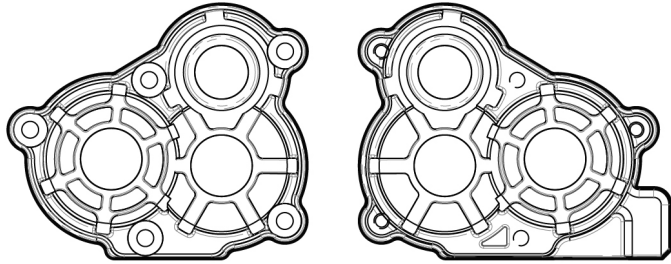

SRD™ Transfer Case Housing
#BRX020047

E GEARBOX / TRANSFER CASE



M2x8 SC x 5
#BRASFCH2008



D2x10 Pin x 2
#BRASPIN210



D5x8x0.5 Spacer x 4
#BRASSPD5805

I GEARS, SHAFTS & BEARINGS - TRANSFER CASE

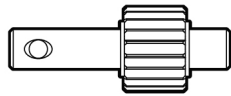

Input Shaft w/ 20T Spur Gear x1
#BRLC7046-A

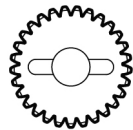

29T Spur Gear x2
#BRLC7046-B

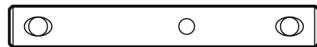

Two Ends Output Shaft x1
#BRLC7046-C

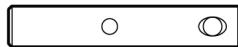

One End Output Shaft x1
#BRLC7046-D



D5x10x4 Ball Bearing x 2
#BBZMR1052RS



D5x14x5 Ball Bearing x 4
#BBZ6052RS

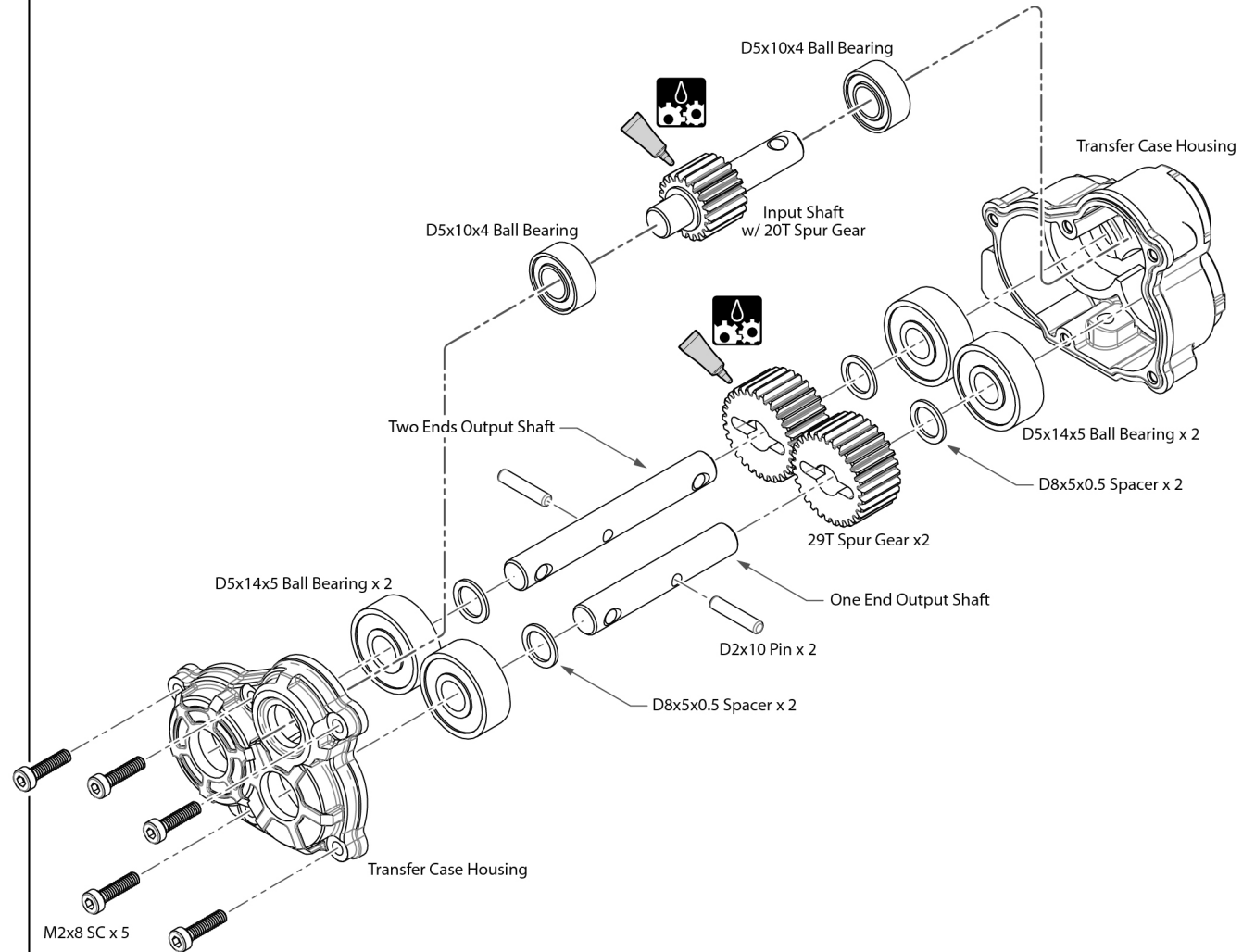





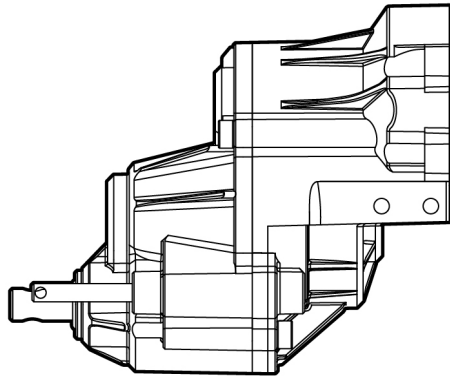

6 - TRANSMISSION

Parts Needed:



Complete **BCF2™** Gearbox

E GEARBOX / TRANSFER CASE

-  M3x8 RS x 4
#BRASBH3008
-  M3x10 CSS x 1
#BRASFH3010
-  M3x6 CSS x 1
#BRASFH3006
-  M2.5x8 SC x 1
#BRASCH2508
-  M3/2.4x12 SS x 2
#BRASST3024/DS
-  D5x7x3 Spacer x 1
#BRASSPD5703

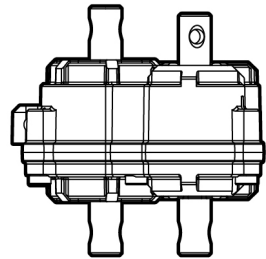

Complete **SRD™** Transfer Case

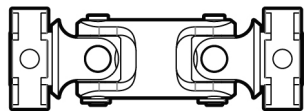

Steel Connection Drive Shaft (33mm)
#BRX020028

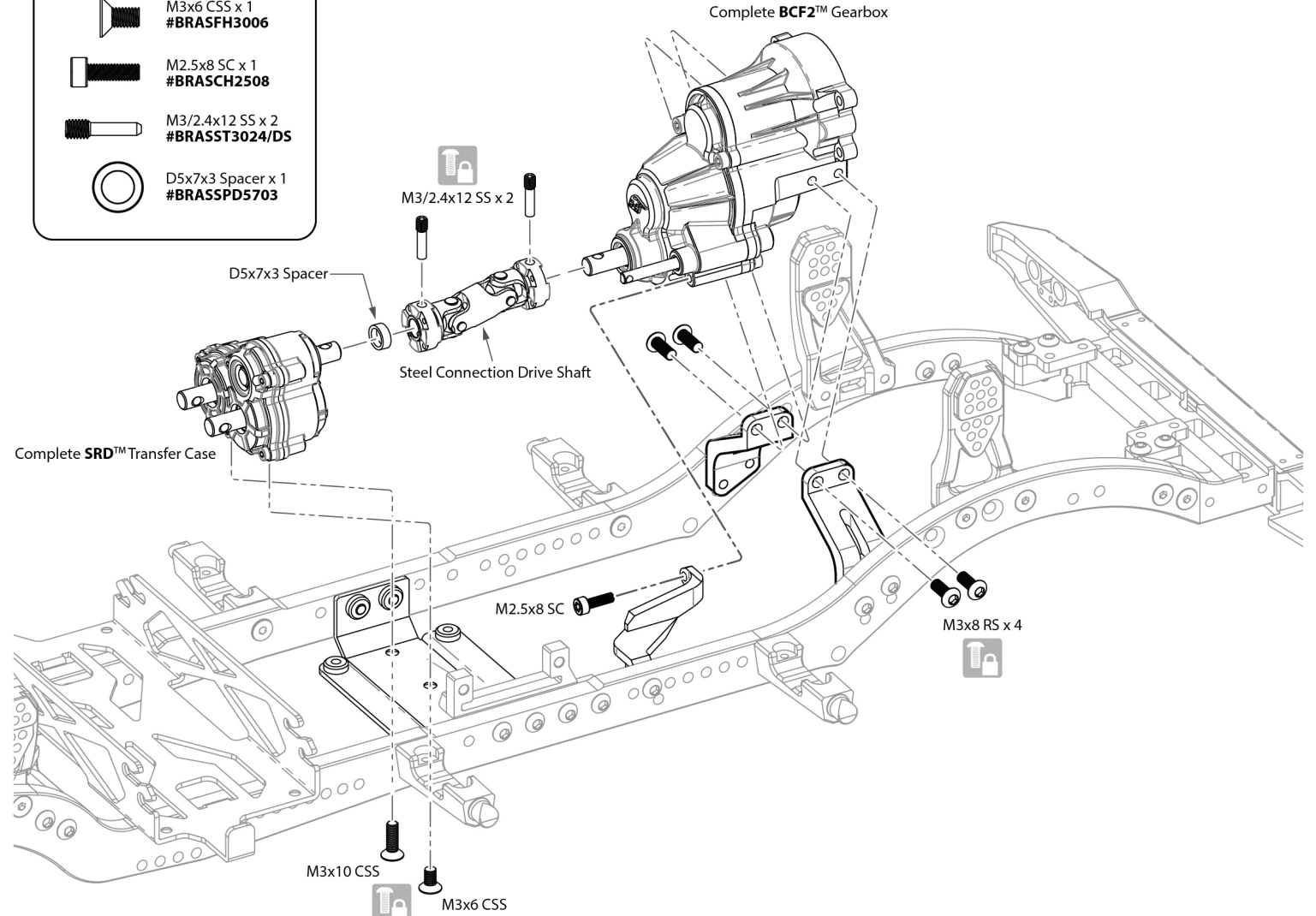

7 - FRONT AXLE & LEAF SPRING

Parts Needed:

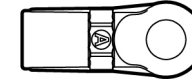
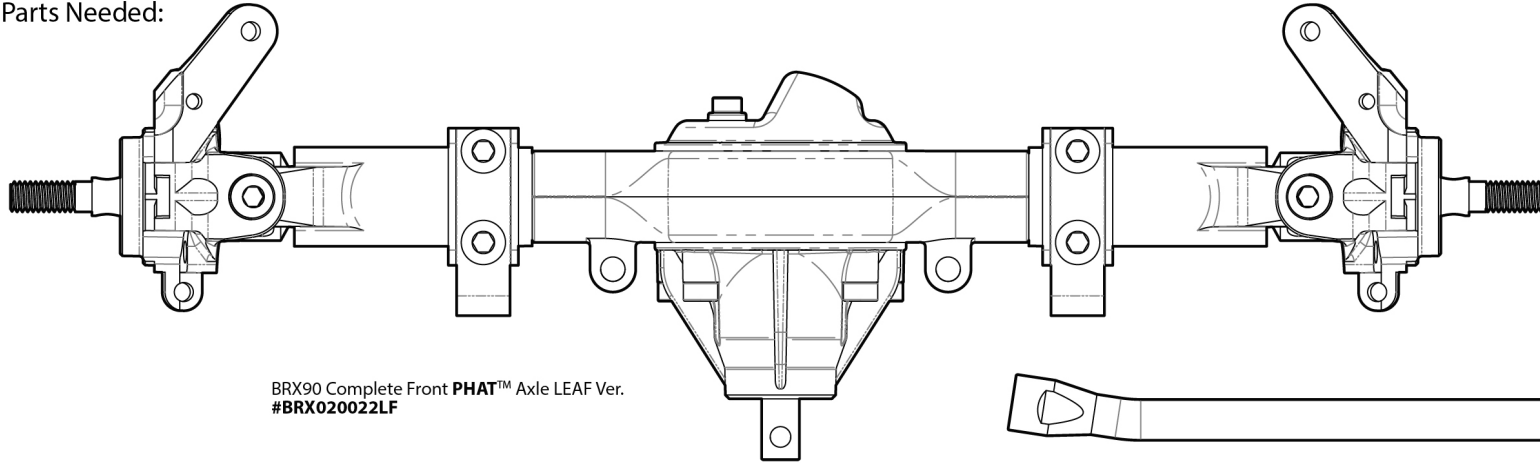

KUDU™
Nylon Rod End
(Straight 18.5mm) x 2
#BRW750306A



BADASS™
Stainless Steel Pivot Ball x 2
#BRW750300

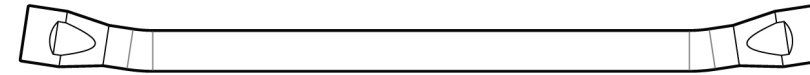

Stainless Steel Tie Rod x 1
#BRD9022A

BRX90 Complete Front PHAT™ Axle LEAF Ver.
#BRX020022LF

B LEAFS / SHOCKS



M4x16 SS x 2
#BRASST4016



D4x7x1
Nylon Spacer x 2
#BRASSPD471/N



D6x1.5 O-Ring x 2
#BRSORD6-15

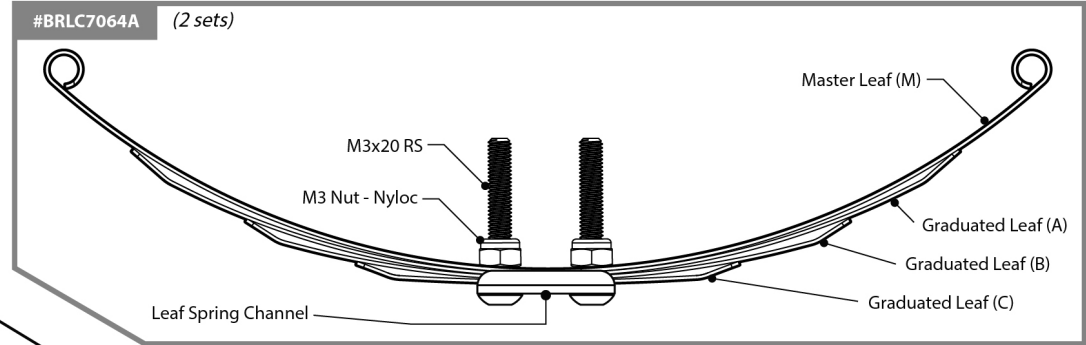

ROD END INSTALLATION

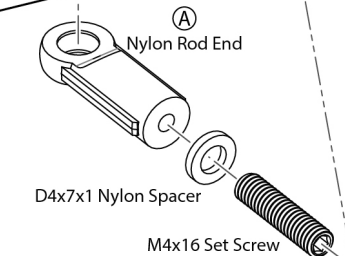
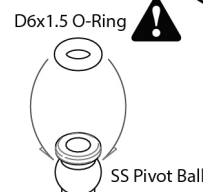
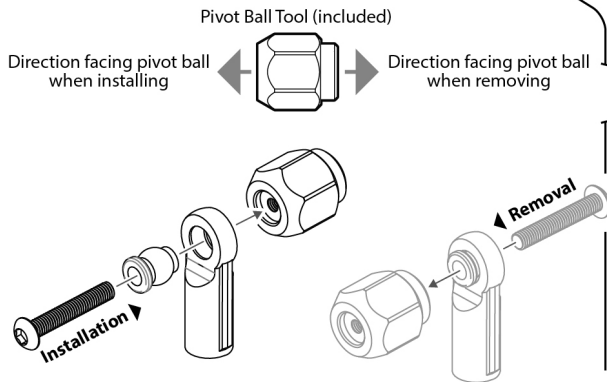

TIE ROD

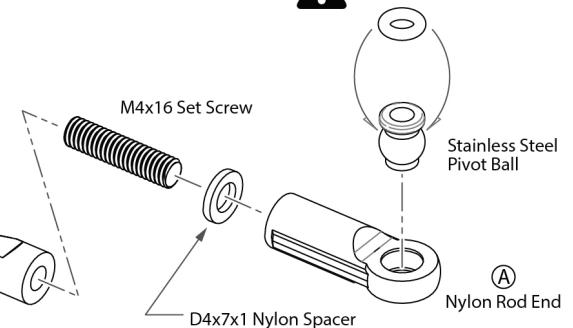
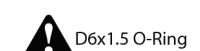
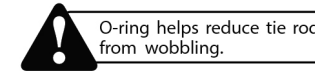

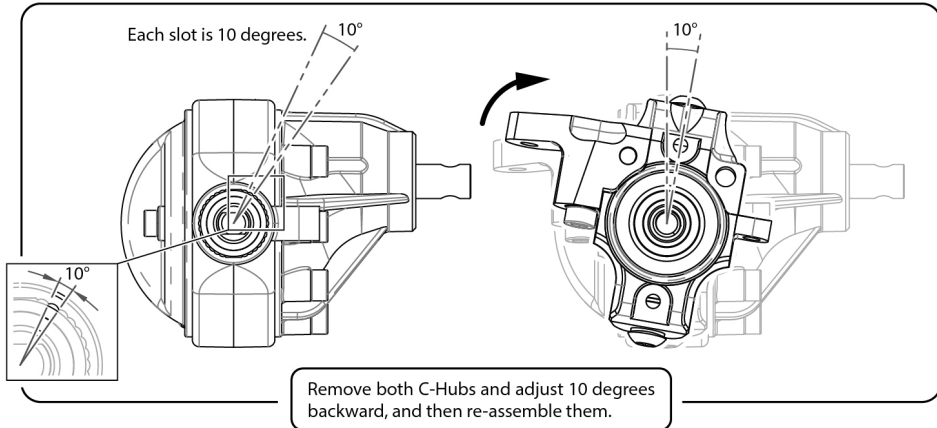

1 Add thread lock to screws on moving parts.

- B LEAFS / SHOCKS**
- M3x24 RS x 1 #BRASBH3024
 - M3x12 RS x 1 #BRASBH3012

LEAF SPRING LOAD SETUP

Weight	# of Leafs	Lightest	Light	Heavy	Heaviest
Heaviest	4				(M)+(A)+(B)+(C)
Heavy	3		(M)+(B)+(C)	(M)+(A)+(C)	(M)+(A)+(B)
Light	2		(M)+(C)	(M)+(B)	(M)+(A)
Lightest	1	(M)			

Recommended stock setup (Front).
 Recommended stock setup (Rear).

3 LEAF SPRING CHANNELS

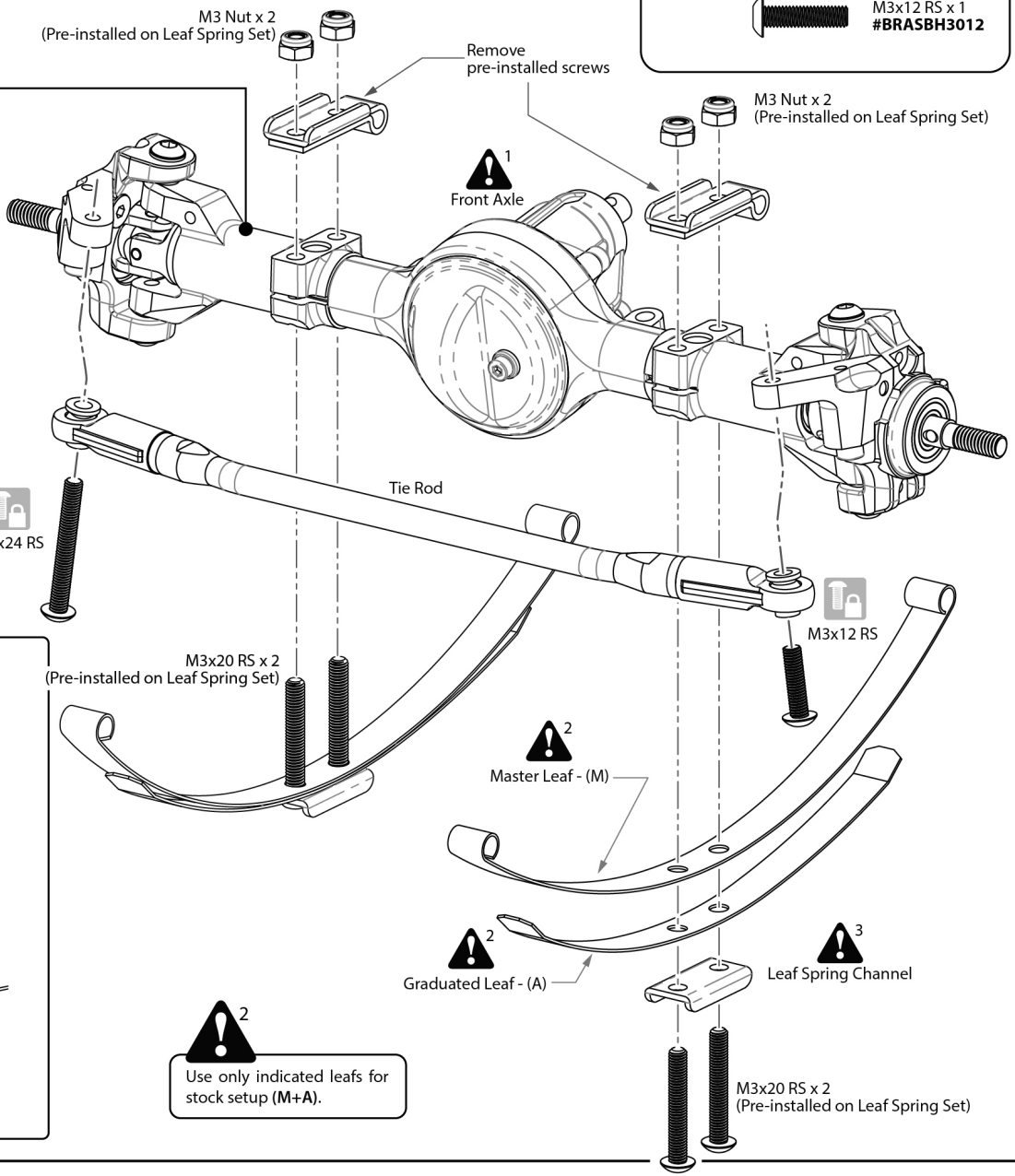
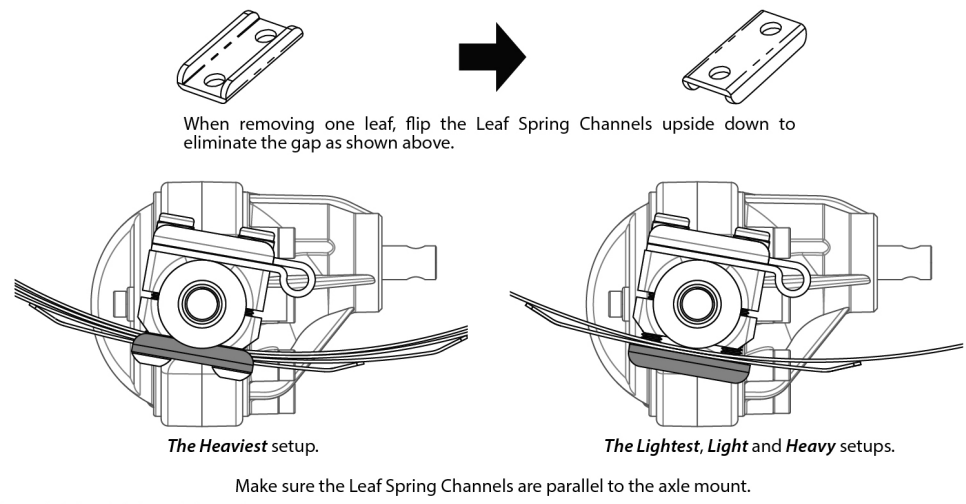

8 - REAR AXLE & LEAF SPRING

Parts Needed:

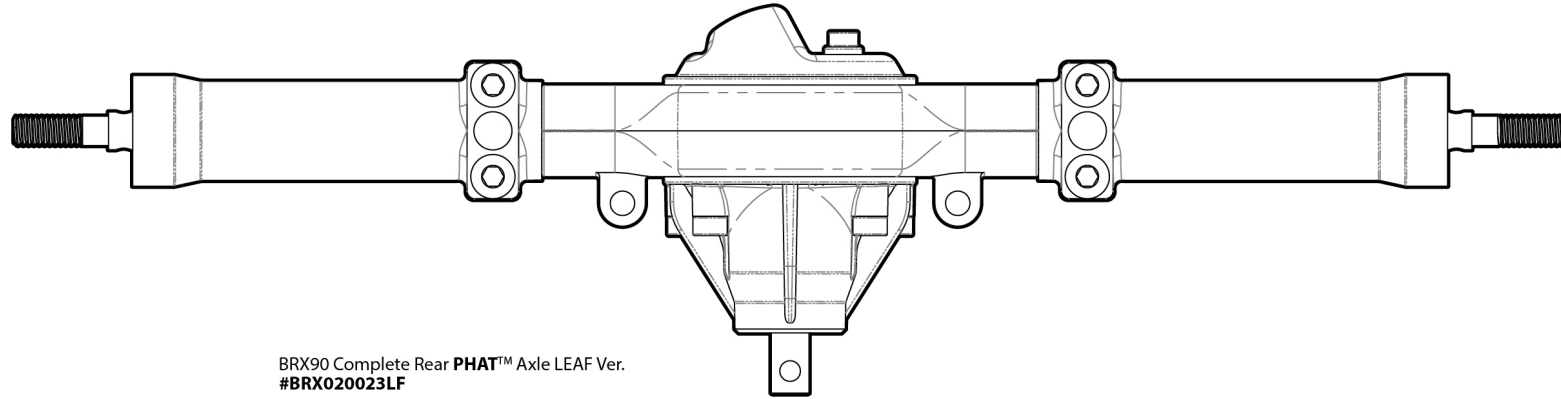

BRX90 Complete Rear PHAT™ Axle LEAF Ver.
#BRX020023LF

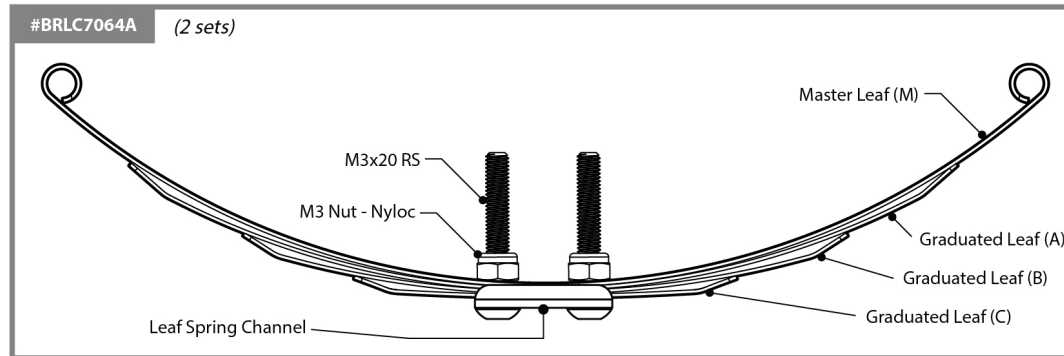

REAR AXLE & LEAF SPRING

REAR AXLE & LEAF SPRING

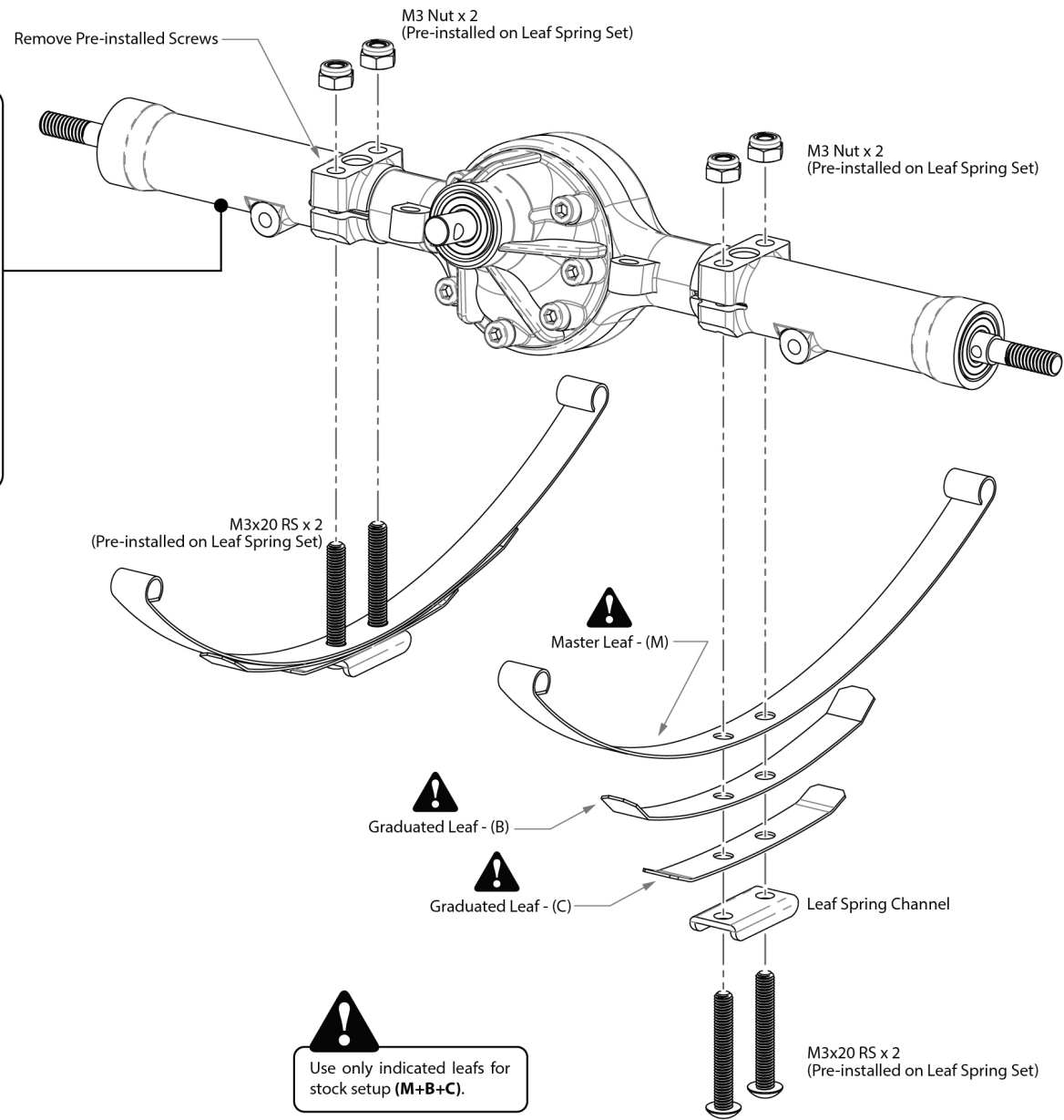
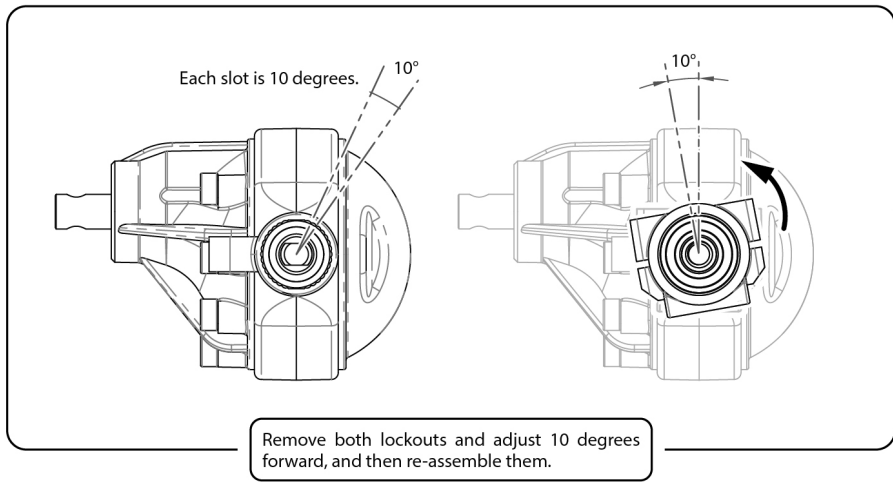

LEAF SPRING LOAD SETUP ⚠

Weight	# of Leafs	Lightest	Light	Heavy	Heaviest
Heaviest	4				(M)+(A)+(B)+(C)
Heavy	3		(M)+(B)+(C)	(M)+(A)+(C)	(M)+(A)+(B)
Light	2		(M)+(C)	(M)+(B)	(M)+(A)
Lightest	1	(M)			

☐ Recommended stock setup (Front).
 ☐ Recommended stock setup (Rear).

9 - LEAF SPRING SYSTEM

Parts Needed:

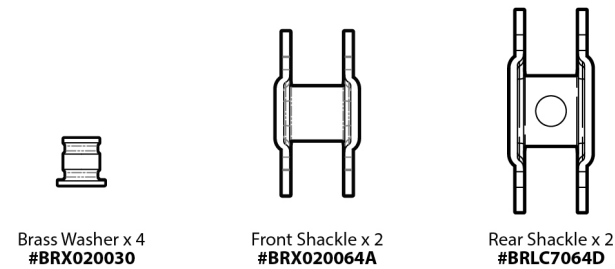
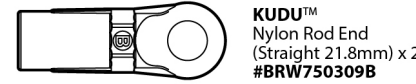
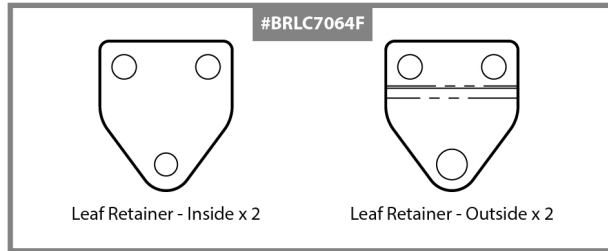
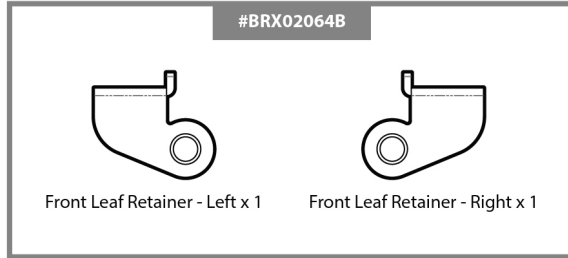

REAR ANTI-WRAP BARS

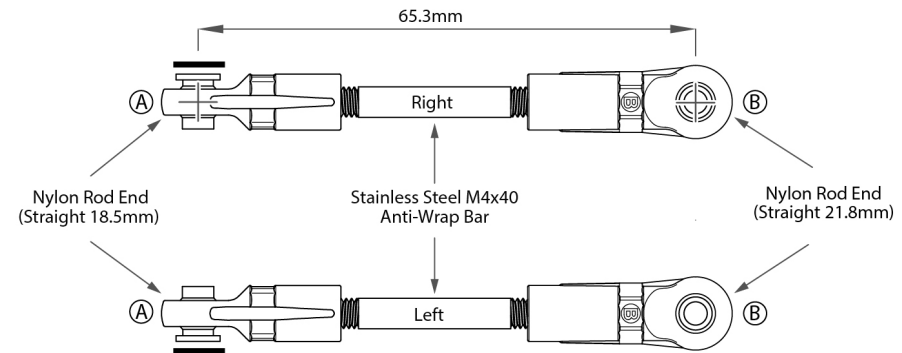

C LEAF SPRINGS

M3x22 RS x 2
#BRASBH3022

M3x12 RS x 2
#BRASBH3012

M3x8 RS x 2
#BRASBH3008

M3x14 Bolt x 4
#BRLC7064E

M3 Nut - Nyloc x 8
#BRASNUTM3

3x6x3
Tapper Spacer x 2
#BRLC7041

D4x7x1
Nylon Spacer x 4
#BRASSPD471/N

 \varnothing 4mm holes face inwards.

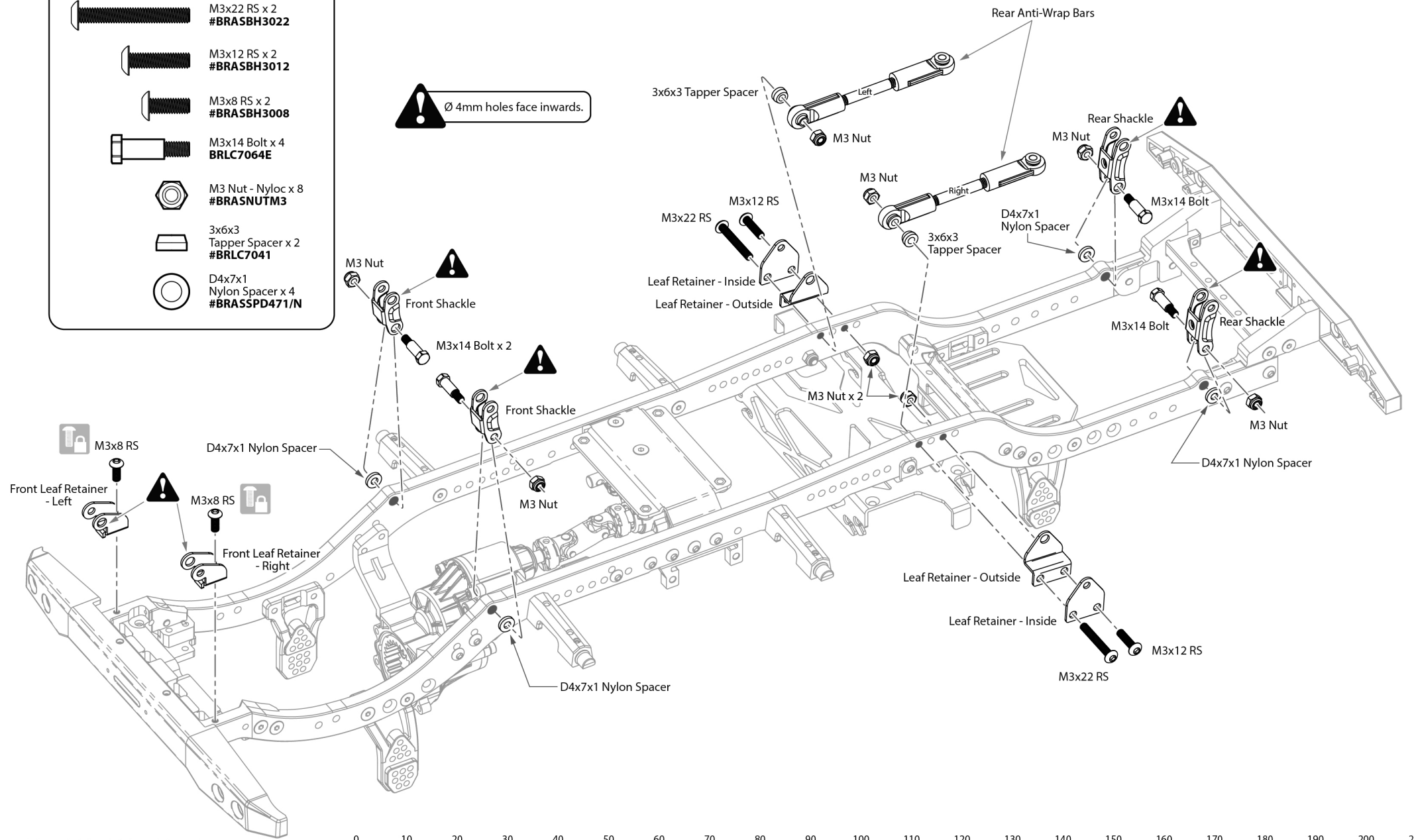

C LEAF SPRINGS



M3x12 RS x 2
#BRASBH3012



D6x1.5 O-Ring x 8
#BRSORD6-15

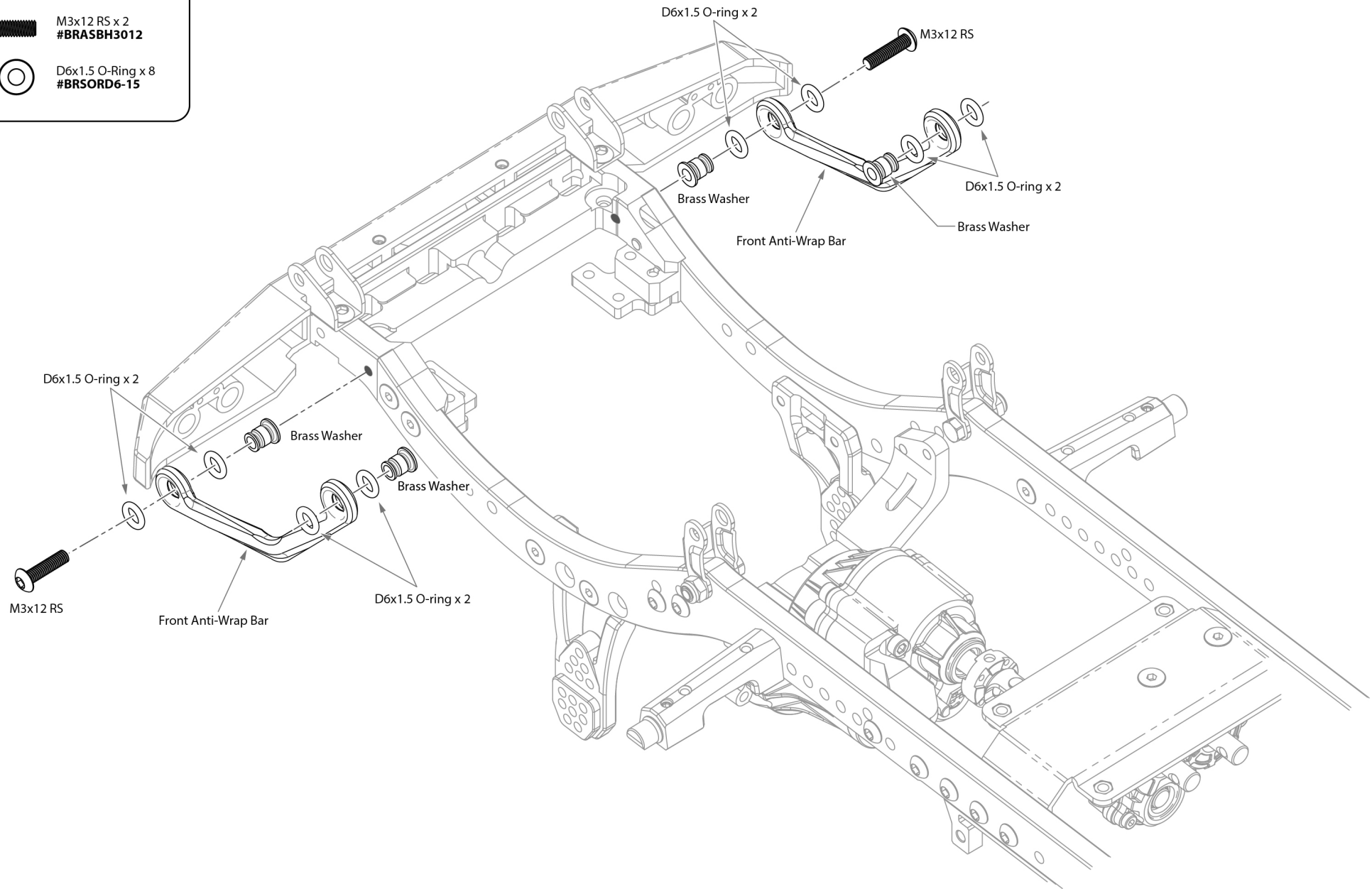

10 - SHOCKS

Parts Needed:

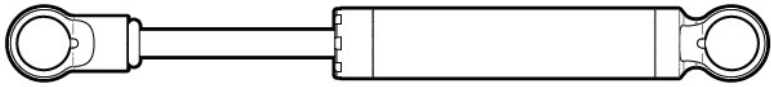

KUDU™ 90mm Scale Shock Absorber x 4
#BRSH0090



Shock End Pivot x 8
#BRW750310



Joint Retainer x 8
#BRSHJR

SHOCKS INSTALLATION & SETUP

1 - 3
Pay attention to cautions 1, 2 and 3.

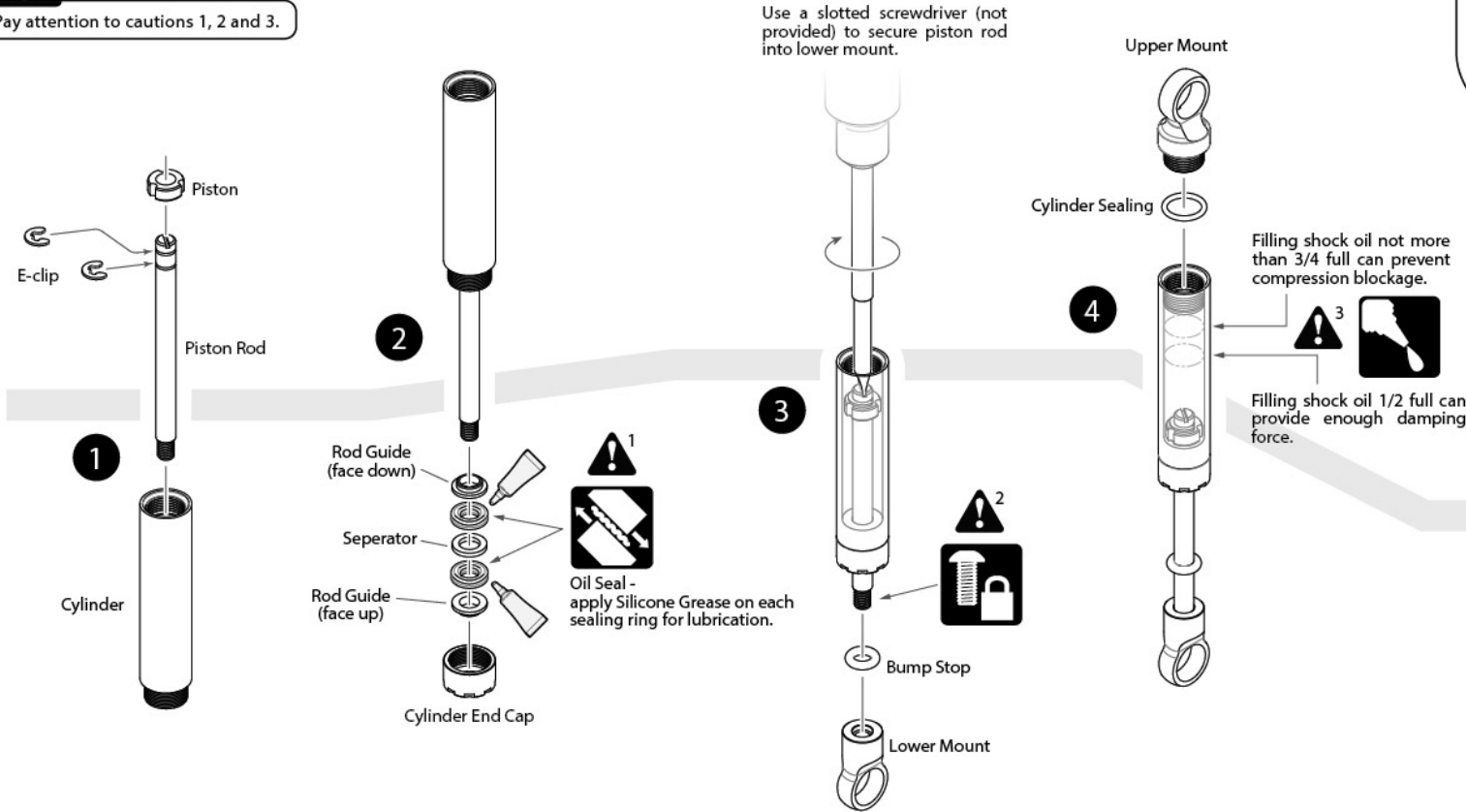

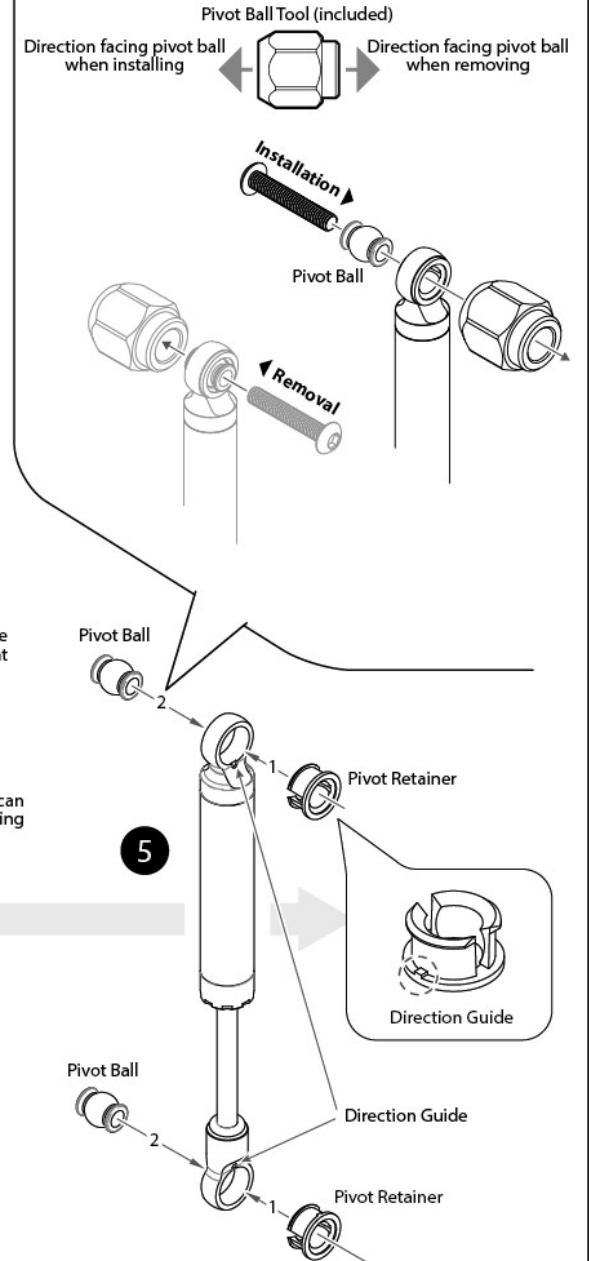

PIVOT BALL INSTALLATION & REMOVAL





DAMPERS

DAMPERS

B LEAFS / SHOCKS

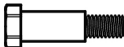

-  M3x24 RS x 2
#BRASBH3024
-  M3x16 RS x 2
#BRASBH3016
-  3x6x3
Tapper Spacer x 2
#BRLC7041

C LEAF SPRINGS

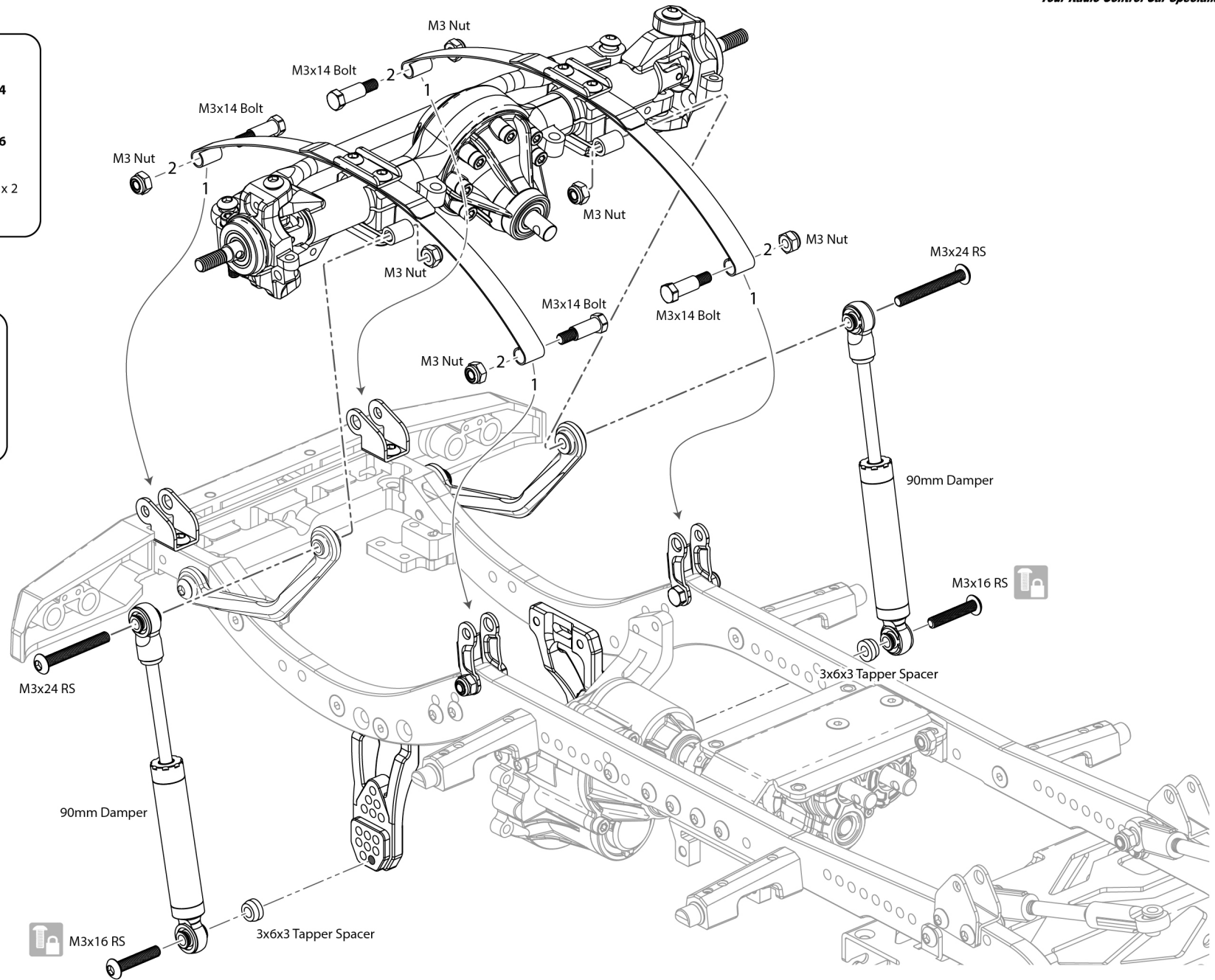

-  M3x14 Bolt x 4
BRLC7064E
-  M3 Nut - Nyloc x 6
#BRASNUTM3



B LEAFS / SHOCKS

-  M3x16 RS x 6
#BRASBH3016
-  3x6x3
Tapper Spacer x 4
#BRLC7041

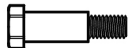
C LEAF SPRINGS

-  M3x14 Bolt x 4
BRLC7064E
-  M3 Nut - Nyloc x 6
#BRASNUTM3

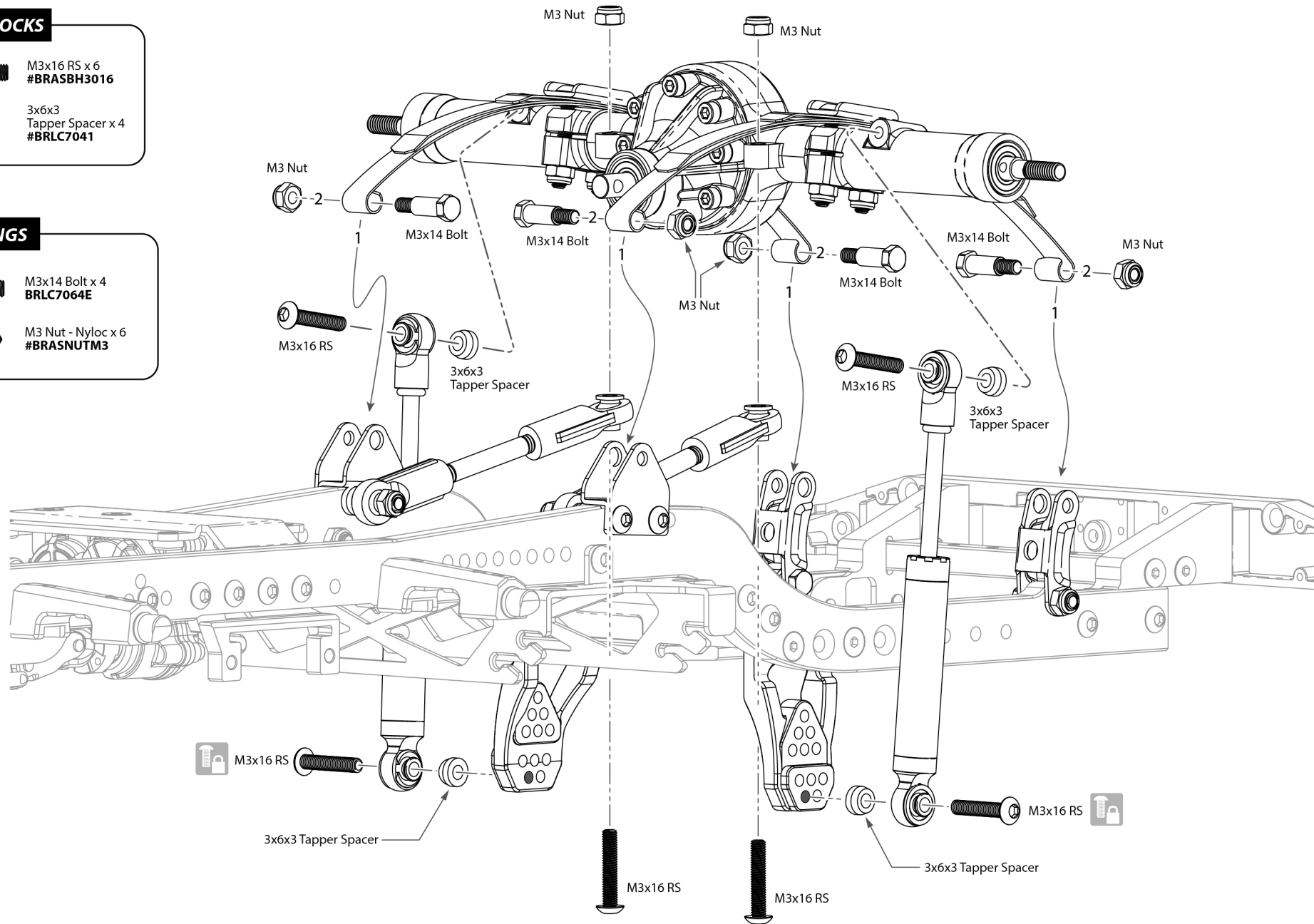

11 - DRIVE SHAFTS

Parts Needed:

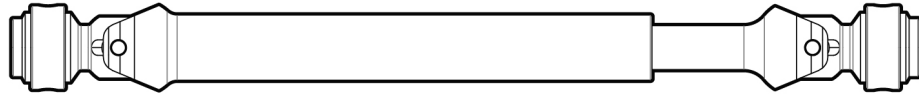

KUDU™ HD CVD Center Drive Shaft x 2
#BRX020043

E GEARBOX / TRANSFER CASE

M3/2.2x11 SS x 4
#BRASST3022/DS

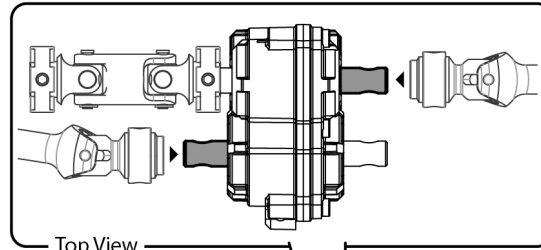
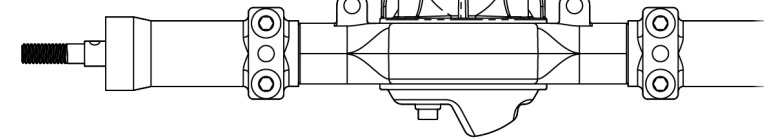
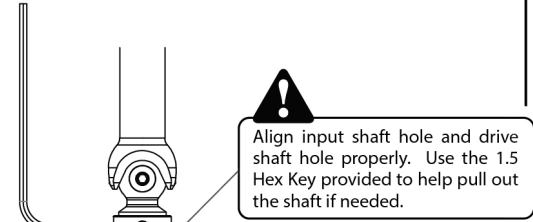

Top View

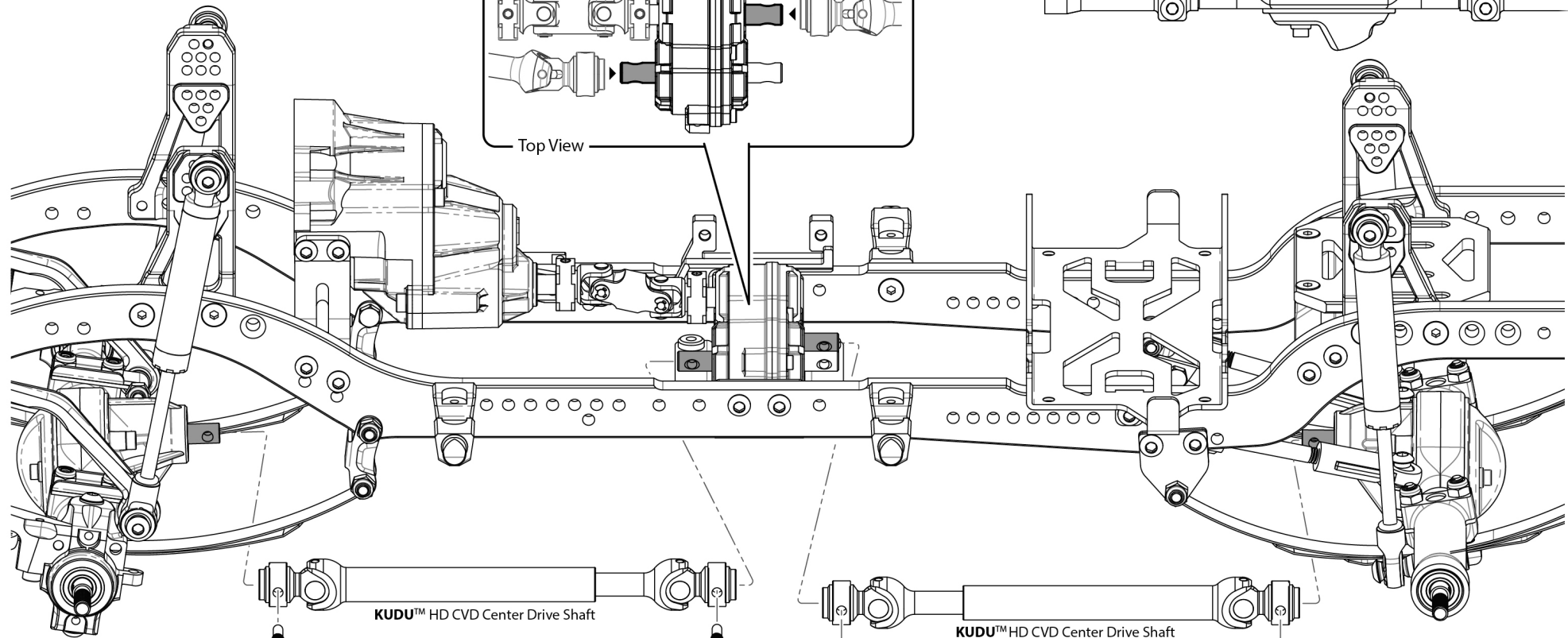

KUDU™ HD CVD Center Drive Shaft

KUDU™ HD CVD Center Drive Shaft

M3/2.2x11 Set Screw x 2

M3/2.2x11 Set Screw x 2

DRIVE SHAFTS

DRIVE SHAFTS

12 - SERVOS & SKID SLIDER

Parts Needed:

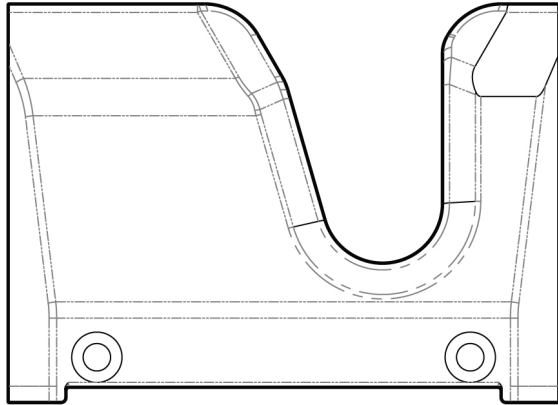

Front Center Skid Slider x 1
#BRX020072F

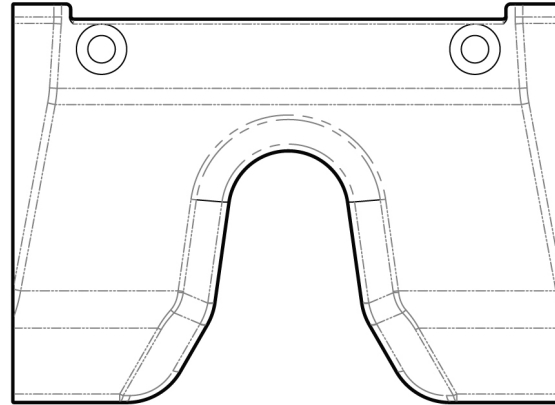

Rear Center Skid Slider x 1
#BRX020072R

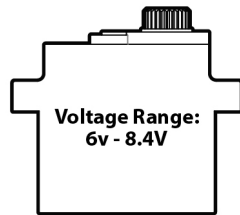

JX Waterproof HV Mini Servo x 1
#JX/PDI-HV1151MG

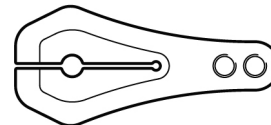

Servo Horn B - 25T x 1
#BRLC7055

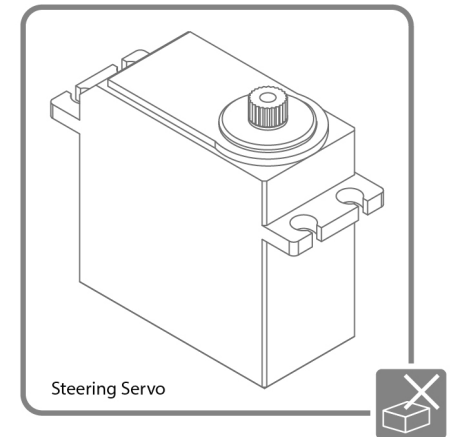

Steering Servo

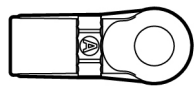

KUDU™
Nylon Rod End (Straight 18.5mm) x 2
#BRW750306A



BADASS™
Stainless Steel Pivot Ball x 2
#BRW750300

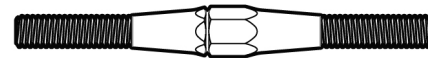

Fine Tunable Link - 55mm x 1
#BRLC7050

H SERVOS

M3x6 RS x 6
#BRASBH3006

JX Waterproof HV Mini Servo

M3x6 RS x 2

M3x6 RS x 4

Steering Servo

JX Waterproof High Voltage Mini Servo Specs:



Model:	JX/PDI-HV1151MG
Working voltage:	6V~8.4V
Working temperature:	-20C°~ +60C°
Dead band:	4usec
Motor type:	Core Motor
Signal booster type:	Digital
Gear material:	Metal gear
Operating Speed:	0.12s/60deg (6.0V) 0.10s/60deg (8.4V)
Stall Torque:	3.5kg/cm (6.0V) 4.5kg/cm (8.4V)
Idle Current:	150mA (6.0V) 180mA (8.4V)
Load Current:	260mA (6.0V) 340mA (8.4V)
Size:	23.2 x 12.5 x 25.6mm
Weight:	15g
Tooth Count:	25
Wire length:	310mm JR plug
Black:	Negative
Red:	Positive
White:	Signal

SERVOS & SKID SLIDERS

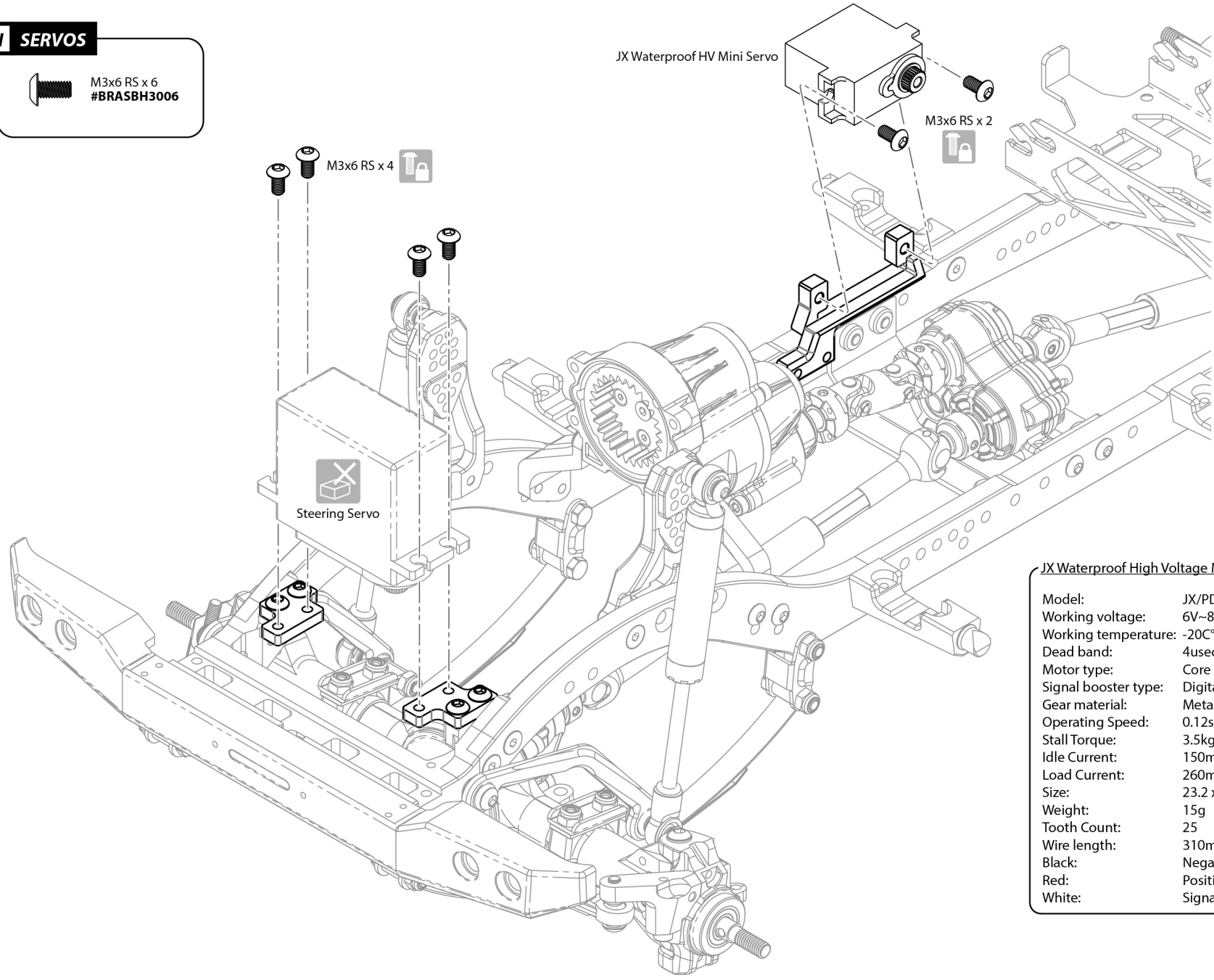

SERVOS & SKID SLIDERS





A CHASSIS

-  M3x14 RS x 4
#BRASBH3014
-  M3x6 RS x 4
#BRASCH3006

B LEAFS / SHOCKS

-  M3x10 RS x 1
#BRASBH3010
-  M3 Nut - Nyloc x 1
#BRASNUTM3
-  3x6x3
Tapper Spacer x 1
#BRLC7041

H SERVOS

-  M3x6 RS x 1
#BRASBH3006
-  M2x8 SC x 2
#BRASCH2008

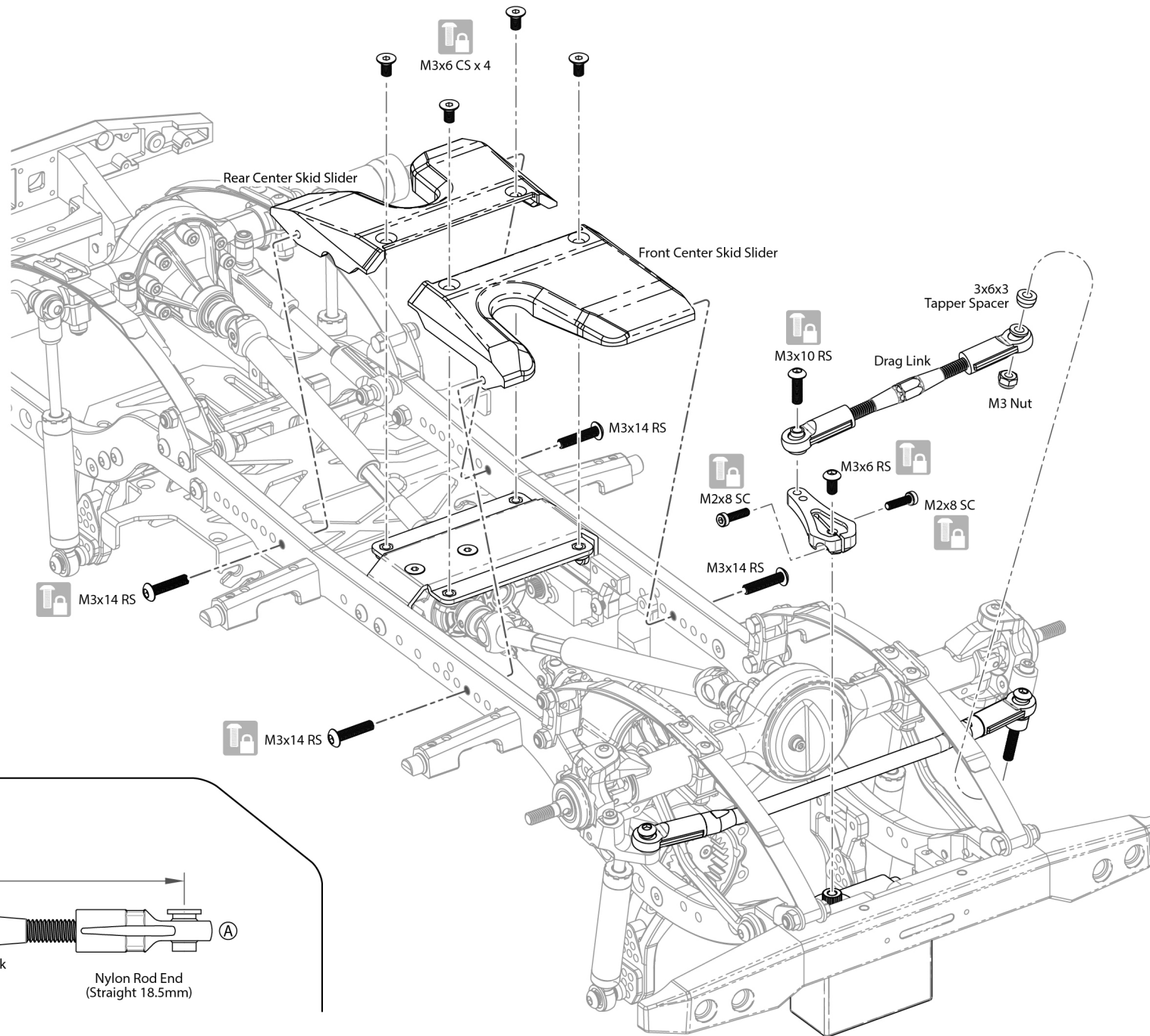

DRAG LINK

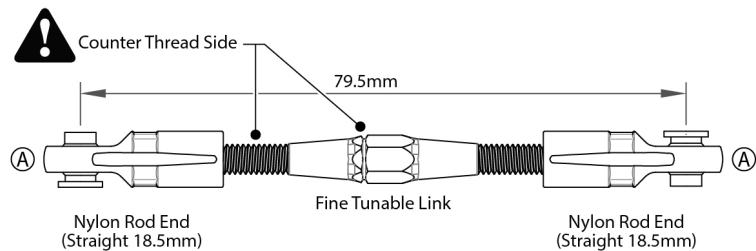

13 - SHIFT ROD

Parts Needed:



Shift Rod x 1
#BRX020051



D2 Ball & Rod End x 1
#BRQ90351

H SERVOS

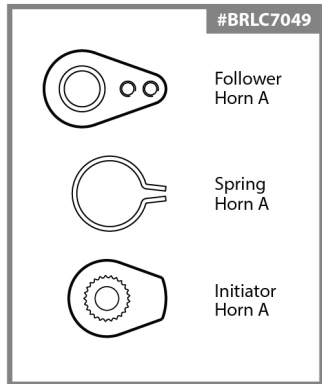

M3x6 RS x 1
#BRASBH3006

M2x8 SC x 1
#BRASCH2008

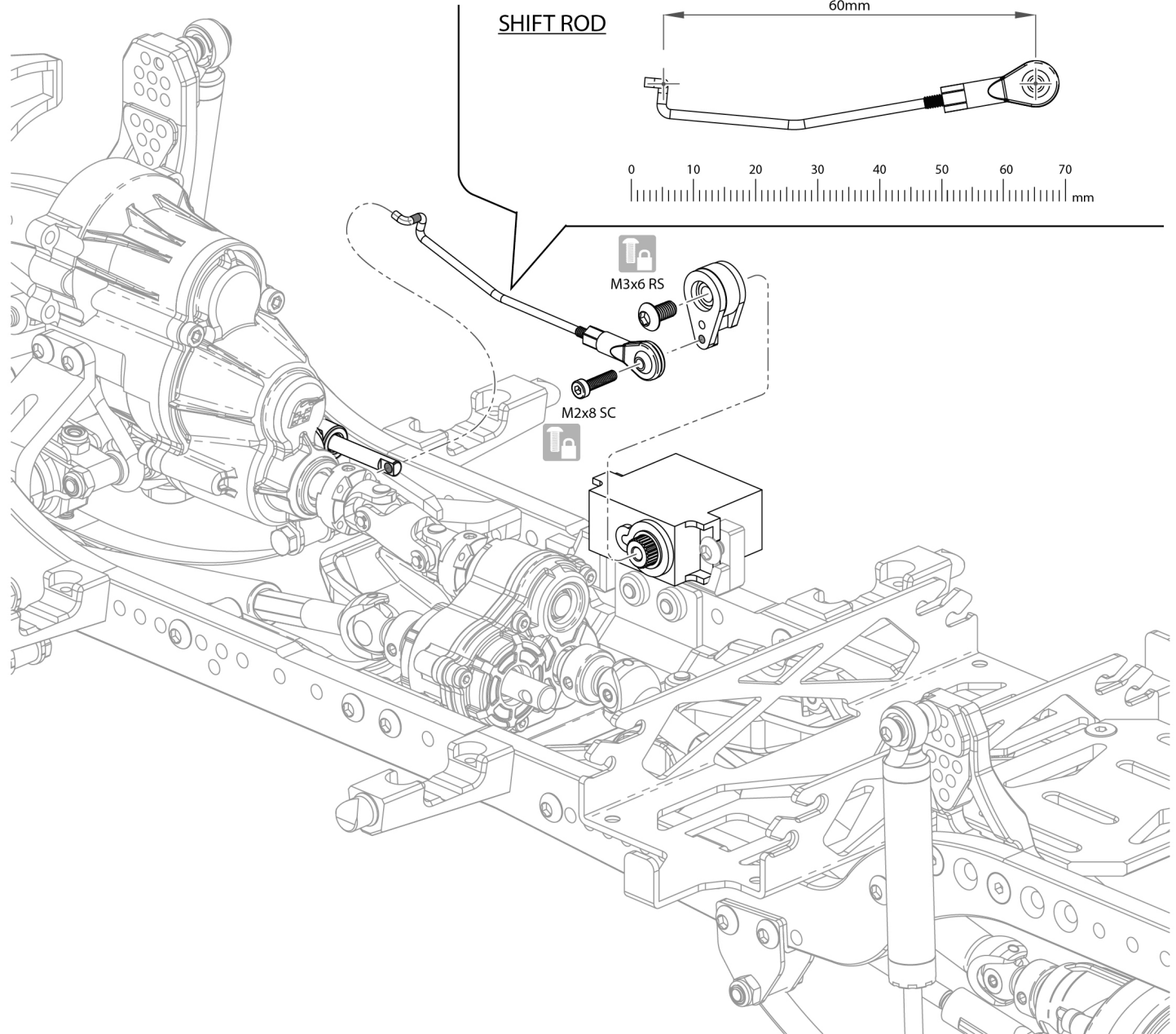

14 - MOTOR

Parts Needed:

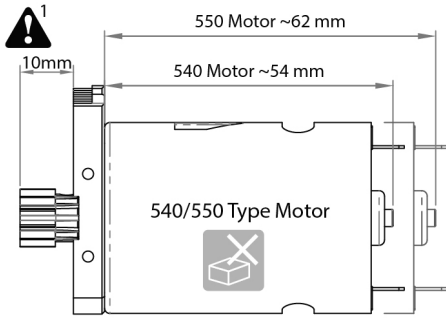

540/550 type motors can be used on BRX02.

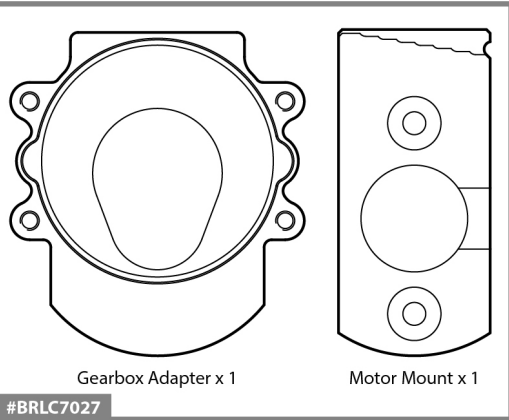

E GEARBOX / TRANSFER CASE

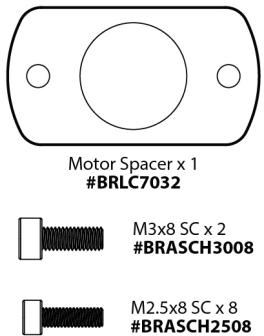

2
Use the corresponding number of the pinion gear tooth (1) on the Motor Mount to get the best gear mesh. Adjust the Motor Mount up and down until both surface indicators (2) are leveled (align at index 12 for the 12T pinion gear supplied as pictured).

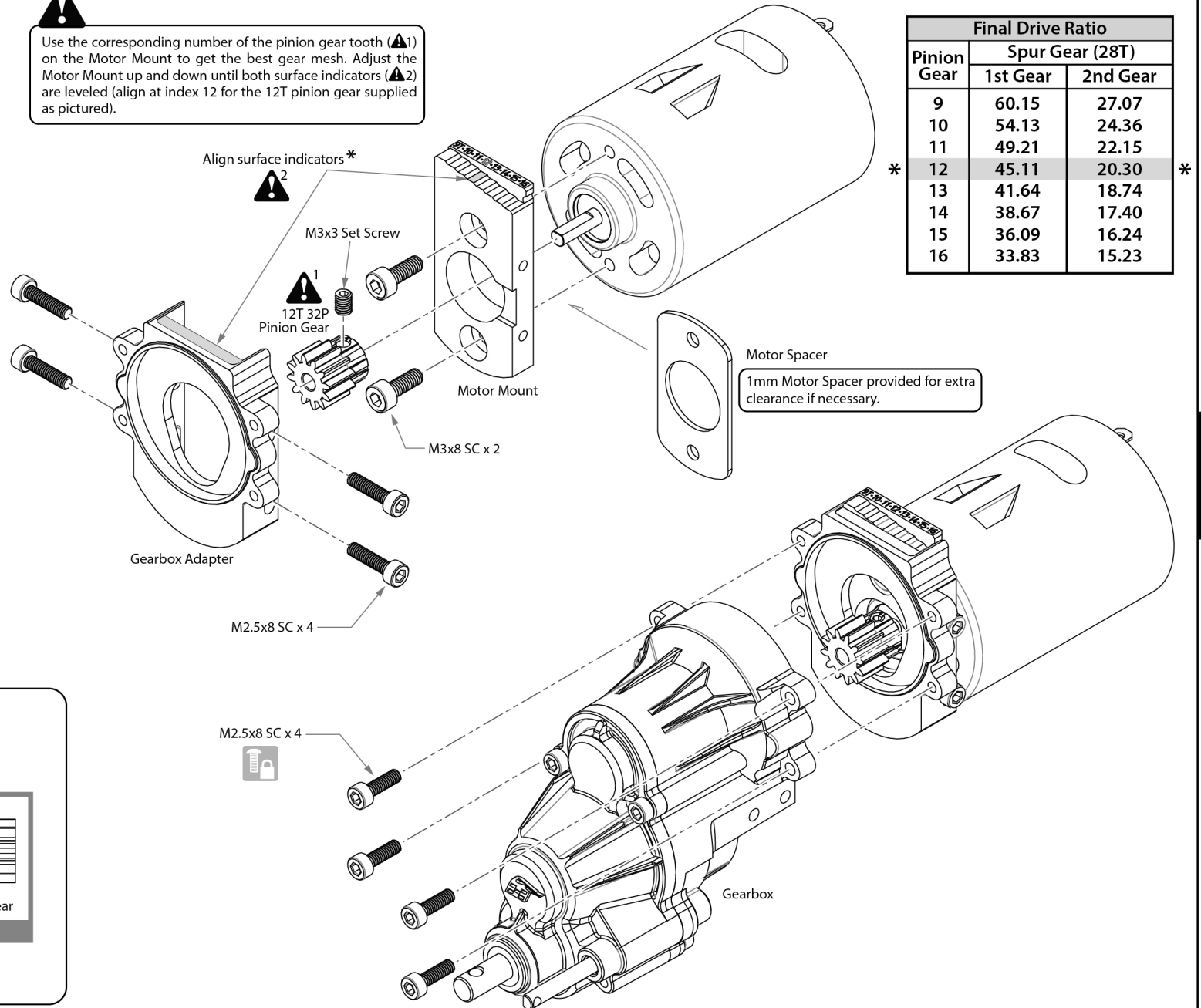

Pinion Gear	Final Drive Ratio	
	Spur Gear (28T)	
	1st Gear	2nd Gear
9	60.15	27.07
10	54.13	24.36
11	49.21	22.15
12	45.11	20.30
13	41.64	18.74
14	38.67	17.40
15	36.09	16.24
16	33.83	15.23

15 - RECEIVER BOX & ELECTRONICS INSTALLATION

Parts Needed:

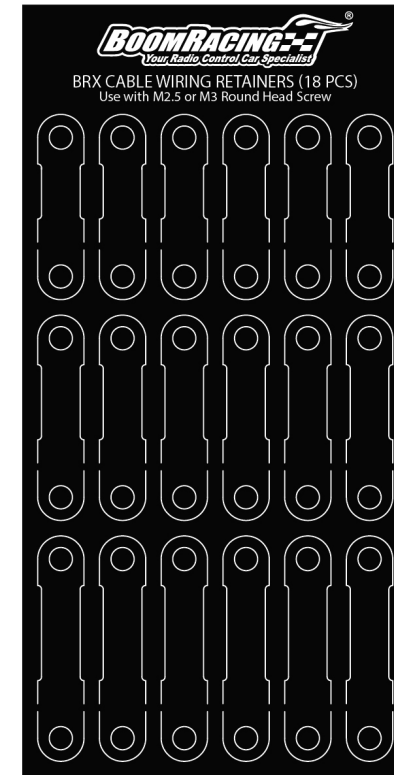
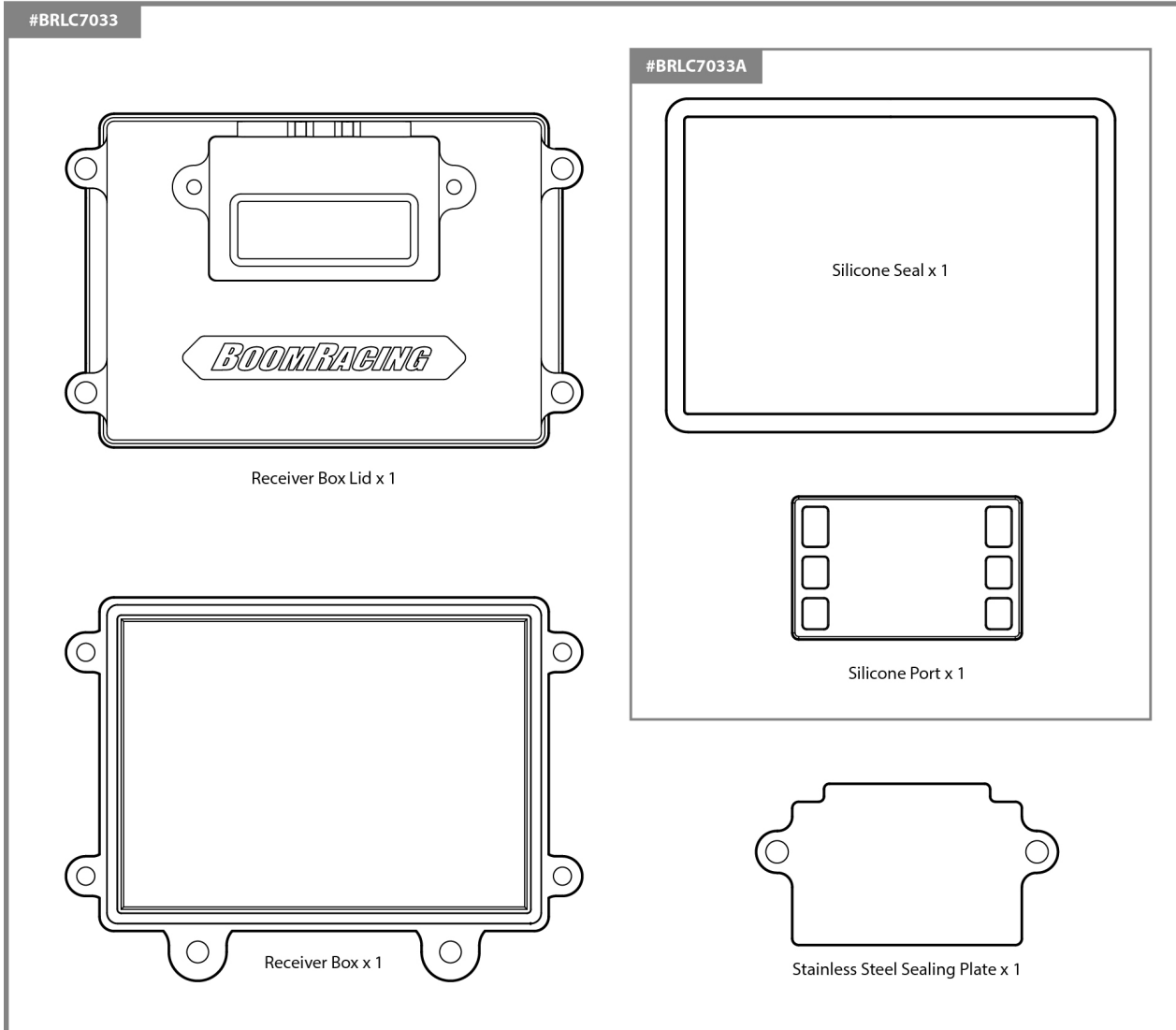

Cable Wiring Retainers
#BRT10037

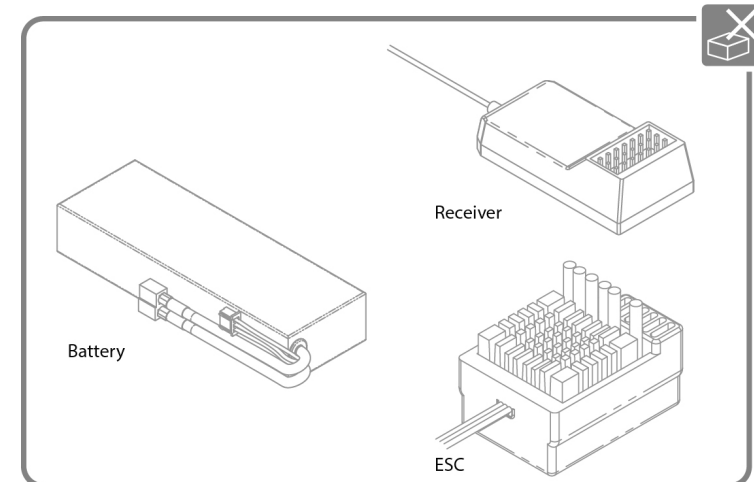

RECEIVER BOX & ELECTRONICS

RECEIVER BOX & ELECTRONICS

F RECEIVER BOX

M3x10 RS x 2
#BRASBH3010

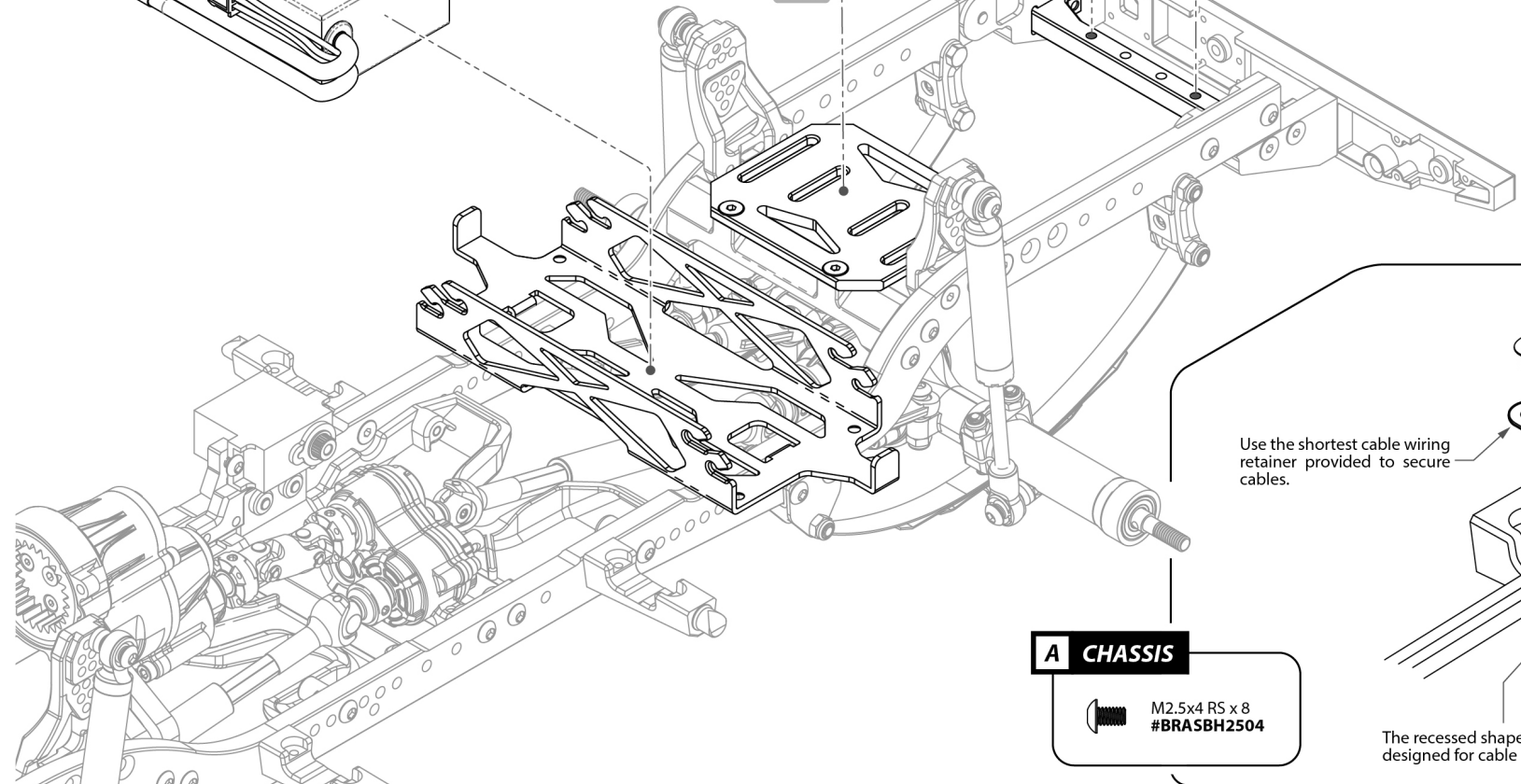
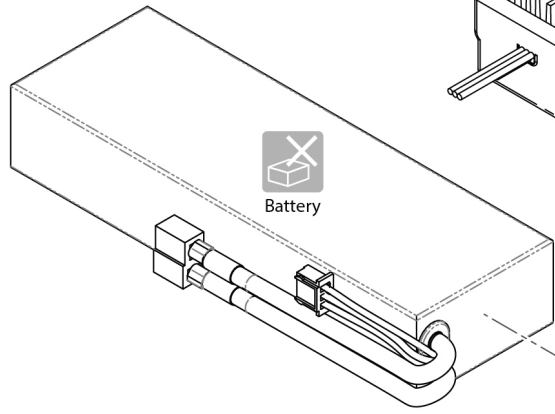
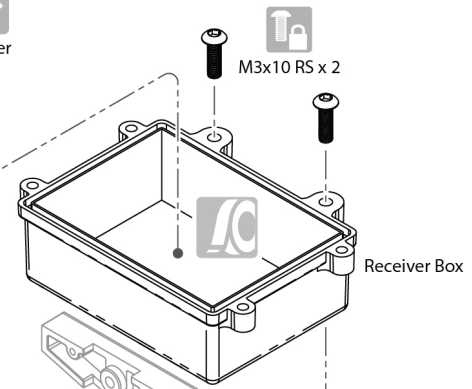
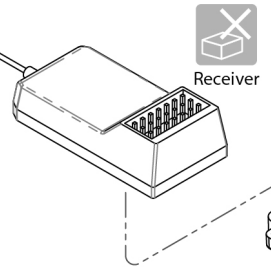
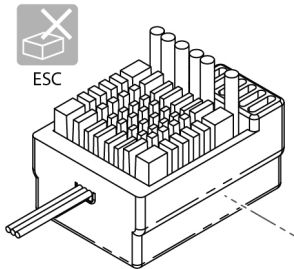

A CHASSIS

M2.5x4 RS x 8
#BRASBH2504

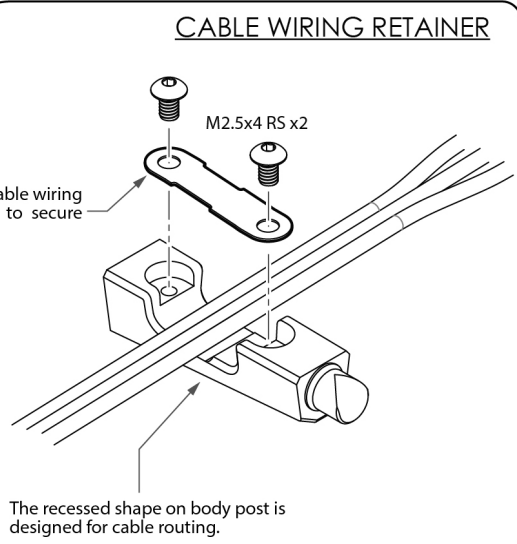

The recessed shape on body post is designed for cable routing.

F RECEIVER BOX

M3x8 RS x 4
#BRASBH3008

M2.5x6 RS x 2
#BRASBH2506

Apply Silicone Grease around and into the silicone sealing to create an airtight seal.

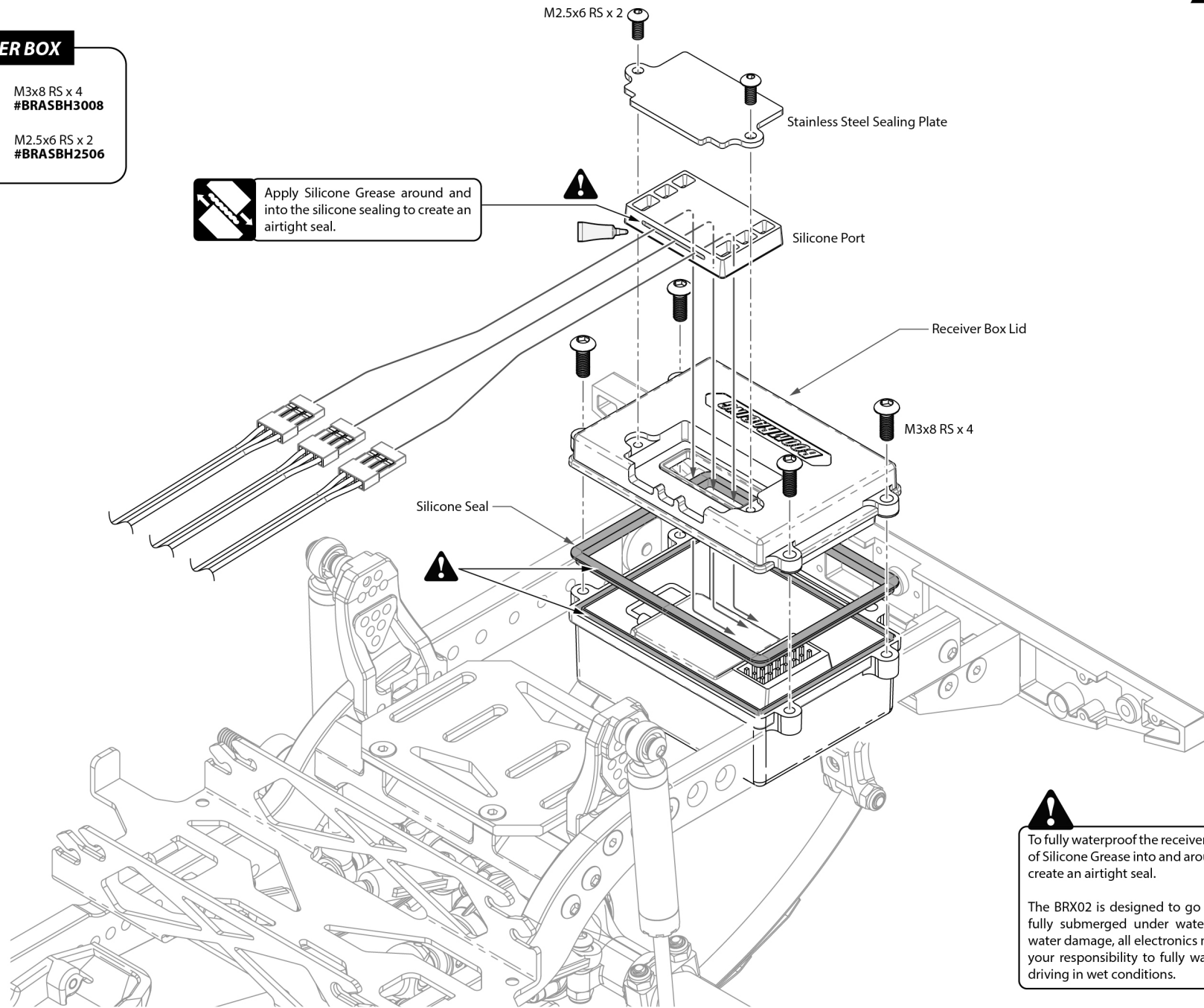

!
To fully waterproof the receiver box, apply a generous amount of Silicone Grease into and around the two silicone sealings to create an airtight seal.

The BRX02 is designed to go anywhere. This includes being fully submerged under water. To protect electronics from water damage, all electronics must be fully waterproofed. It is your responsibility to fully waterproof all electronics before driving in wet conditions.

16 - WHEELS & TIRES

Parts Needed:

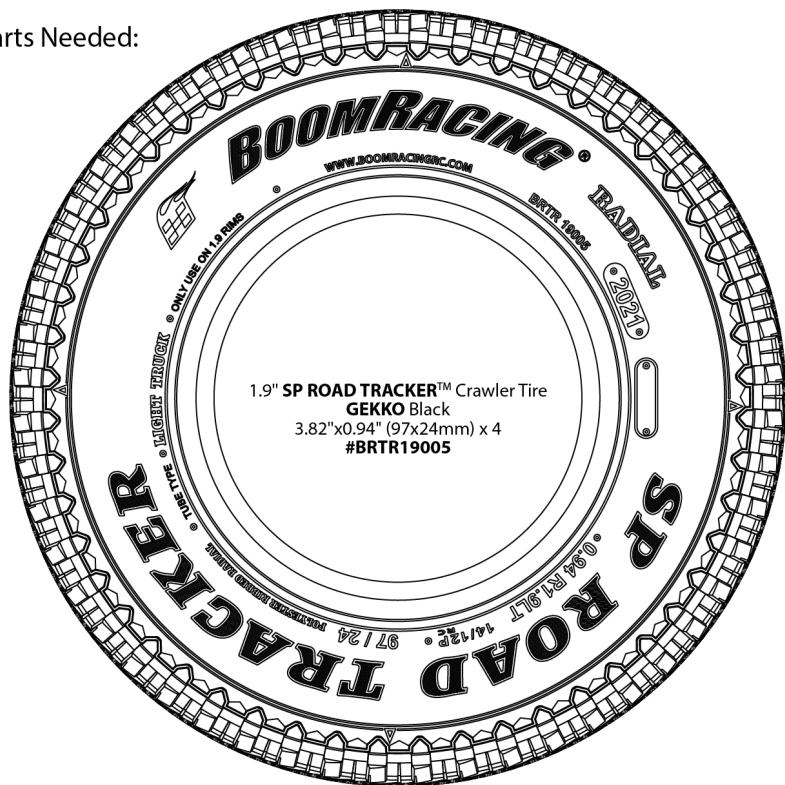

1.9 Single Stage Open Cell Foam Insert
for 1.9" SP ROAD TRACKER™ Crawler Tire x 4
#BRTR39005

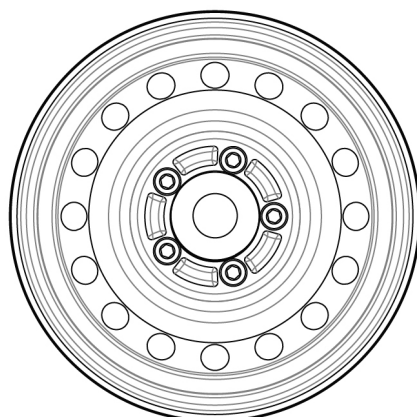

1.9" Narrow 16-Hole Classic Steelie Reversible Beadlock Wheels (Gun Metal) x 4
#BRW780920GM
with XT500 (#BRXT500V2) Wheel Hub



S100 Scale Center Wheel Hub Cap x 4
#BRW780923

C LEAF SPRINGS

 M2.5x14 RS x 2
#BRASBH2514

 2.5 Nut x 2
#BRASNUTM25

D WHEELS

 M4 Nut - Nyloc x 4
#BRASNUTM4

 2x10mm Pin x 4
#BRASPIN210

 D4x7x3
Aluminum Spacer x 4
#BRASSP473

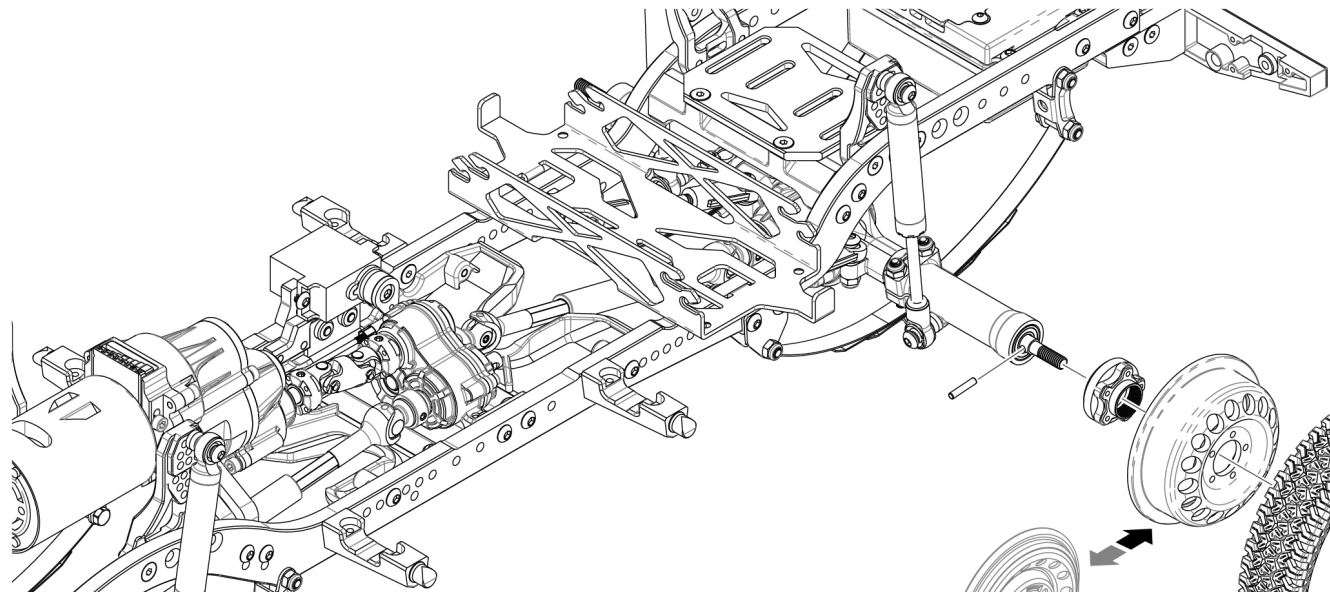

STANDARD SETUP

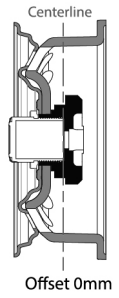
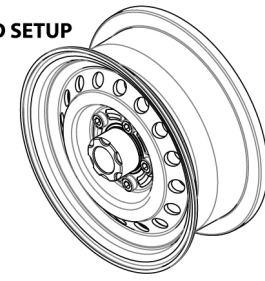

DEEP DISH SETUP

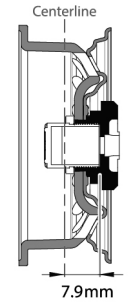
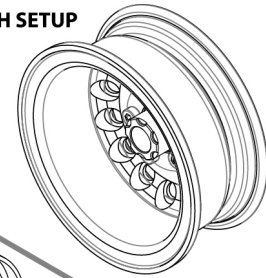

DEEP DISH SETUP

DEEP DISH SETUP

DEEP DISH SETUP

DEEP DISH SETUP

1
Evenly distribute foam within the tire interior before installing beadlock ring.

2

STEERING ANGLE LIMITER

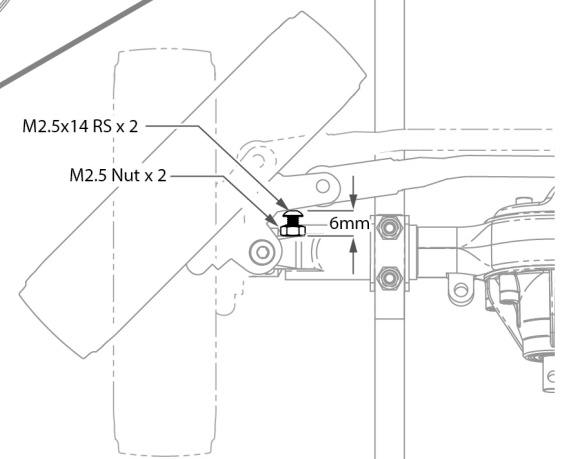

D2x10 Pin

XT500 5-Lug
Aluminum 12mm Wheel Hub Adapter
0mm Offset V2
#BRXT500V2

Wheel Back Piece
#BRW780920B (Narrow)

SP ROAD TRACKER™ Tire

Wheel Center Piece
#BRW780920C (Narrow)

Front Faceplate
#BRW780919A

M2x10 SC x 5
#BRASCH2010

D4x7x3
Aluminum Spacer
#BRASSP473

M4 Nut





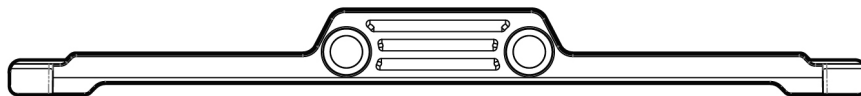
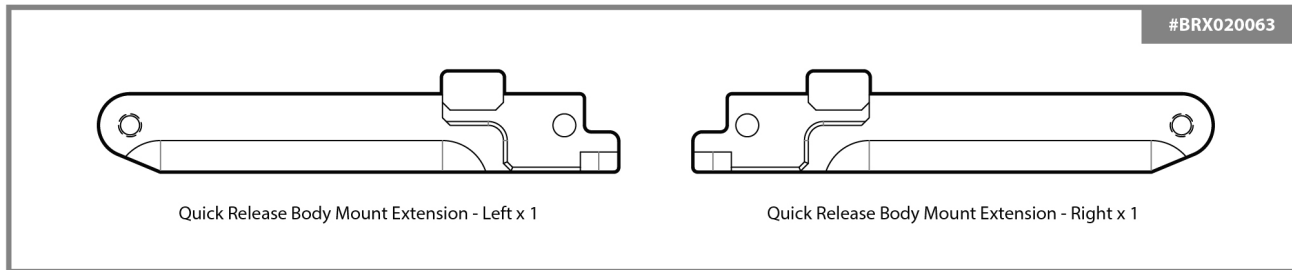
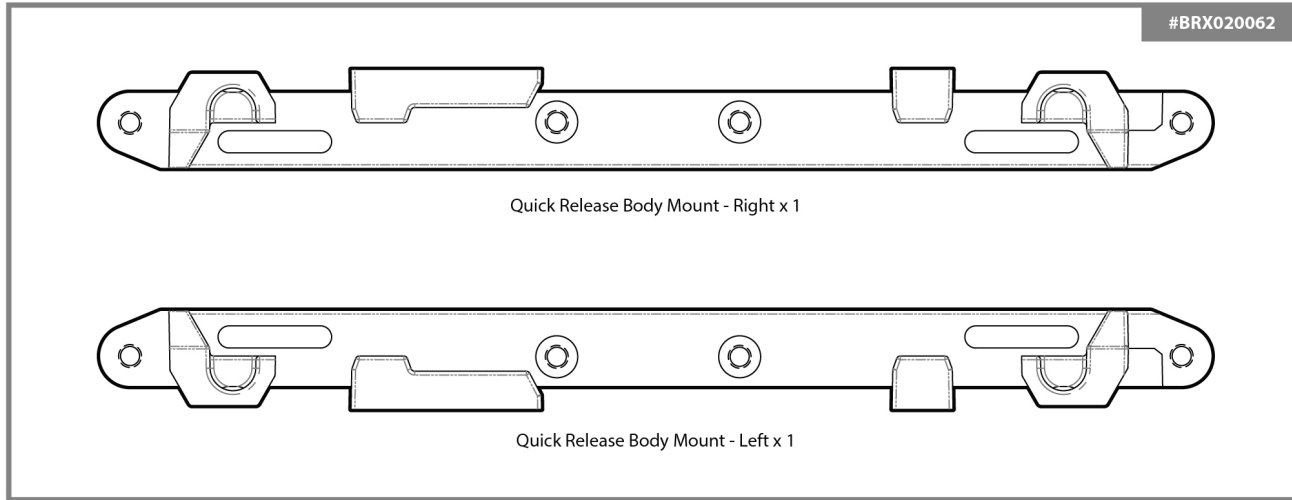

S100 Scale Center Wheel Hub Cap
#BRW780923

17 - BODY MOUNT

Parts Needed:



G BODY MOUNTS

-  M3x14 RS x 4
#BRASBH3014
-  M3x10 RS x 2
#BRASBH3010
-  M3x8 RS x 4
#BRASBH3008
-  M2.5x6 SC x 2
#BRASCH2506
-  Ø5mm Spring x 4
#BRASSPRING05510
-  Slider Spacer x 4
#BRX020035

QUICK RELEASE BODY MOUNT - LEFT

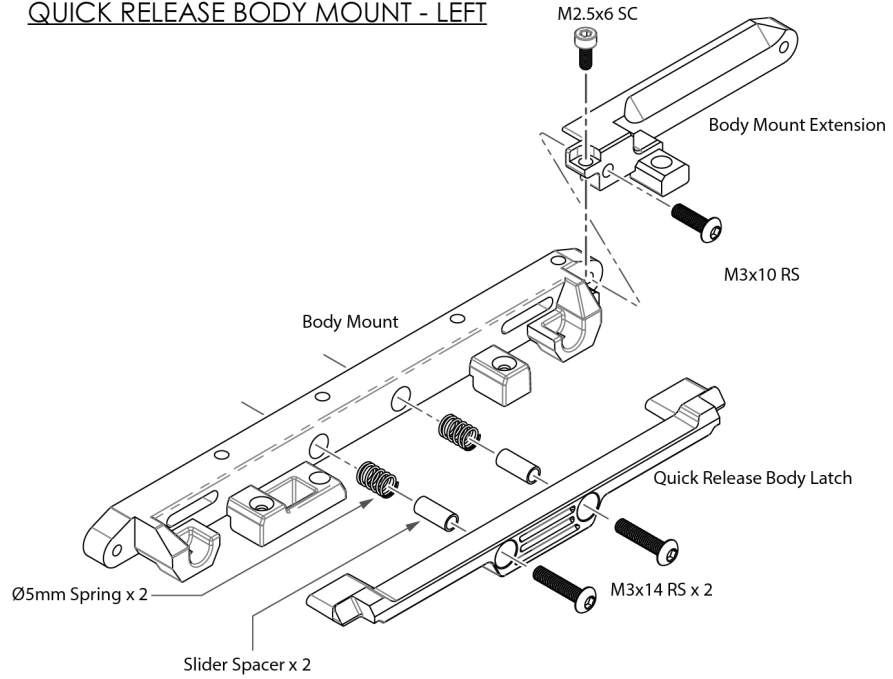

QUICK RELEASE BODY MOUNT - RIGHT

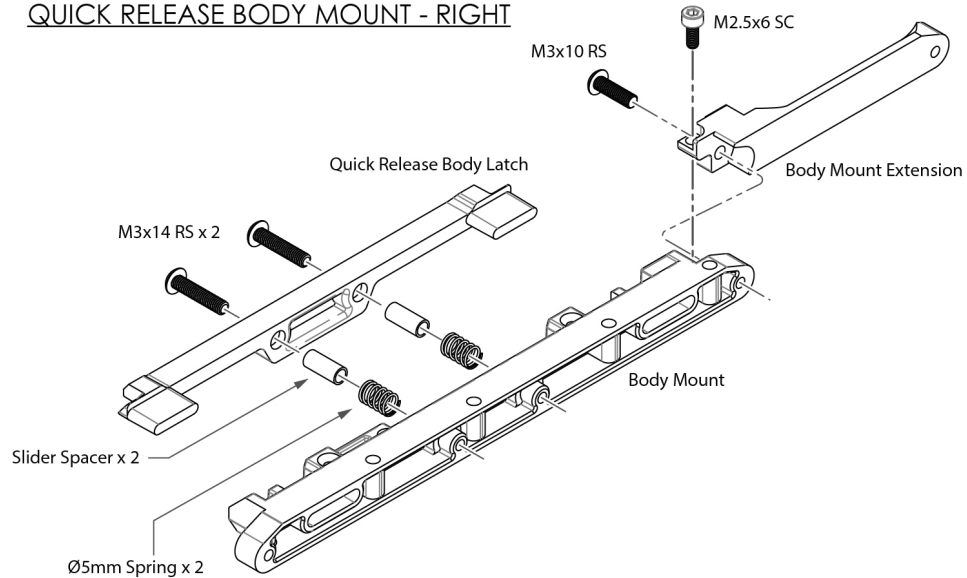

Refer to page 58 for interior opening.

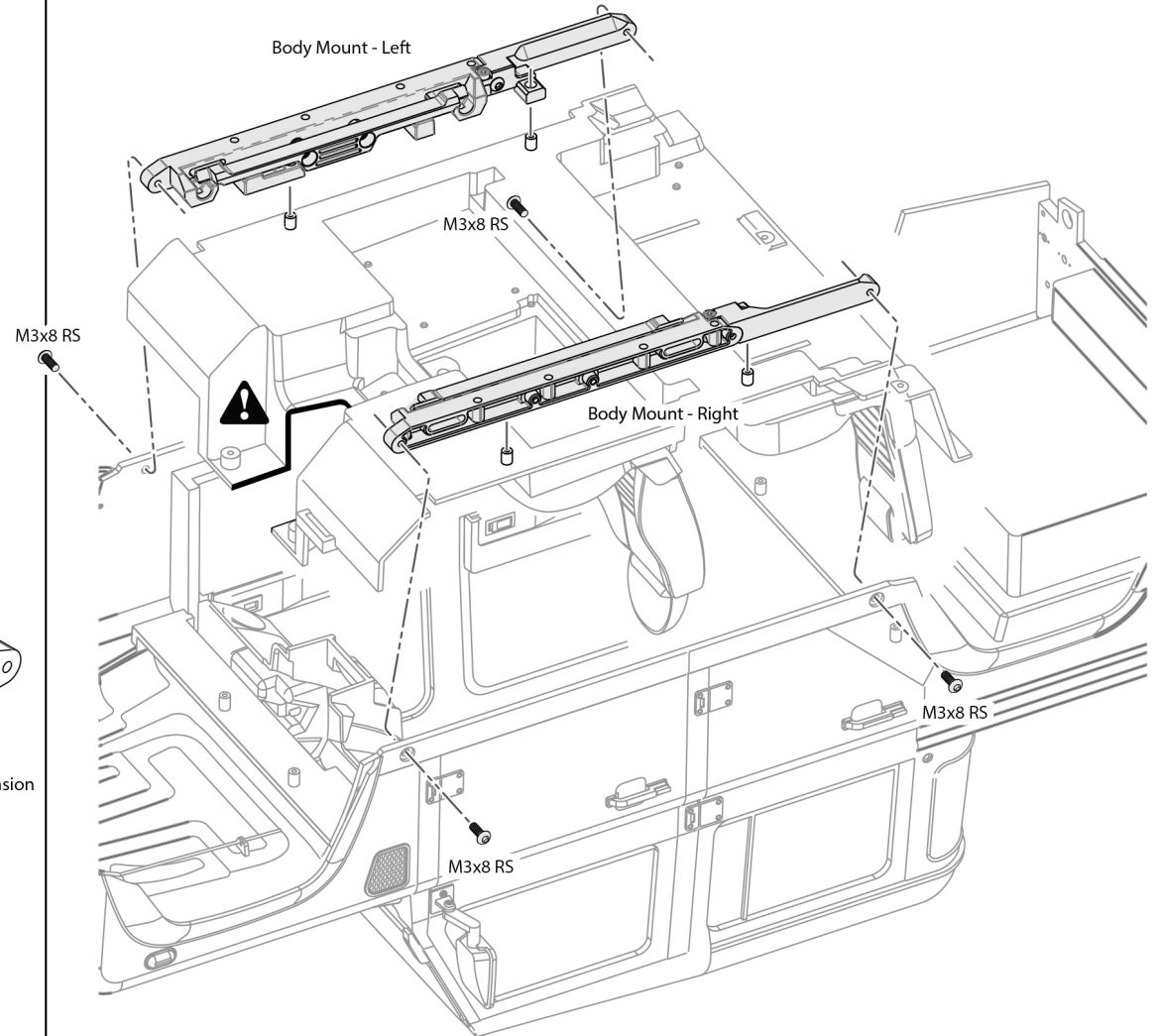

ATTACH / DETACH BODY

!
After inserting the retainers to the rear bumper (1), place the D110 body onto the chassis and push firmly into the body mount brackets (2) to secure the body.
To release the body, compress both left and right body latches (3).

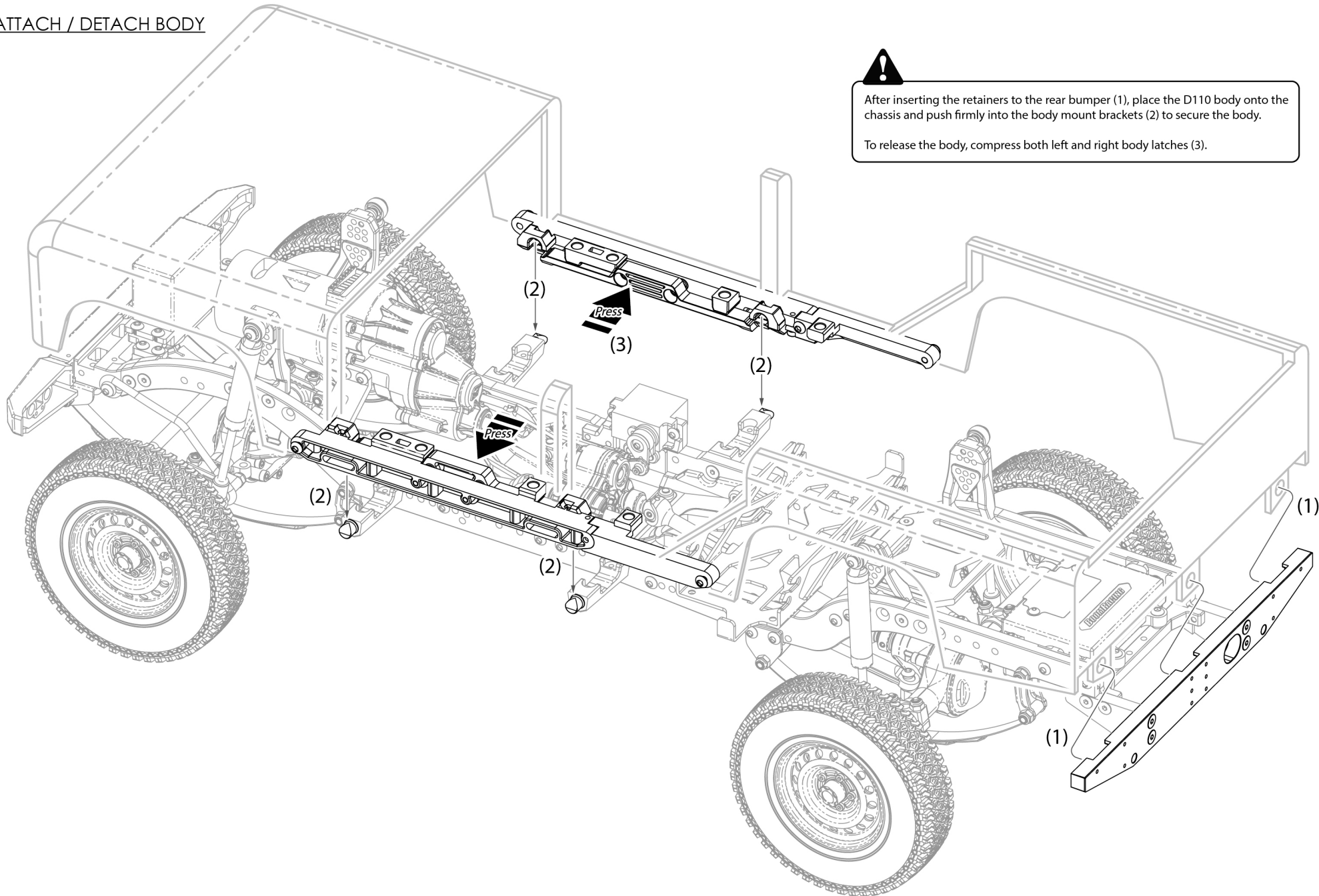

BODY MOUNT

BODY MOUNT

18 - OPTIONAL LED INSTALLATION

Parts Needed:

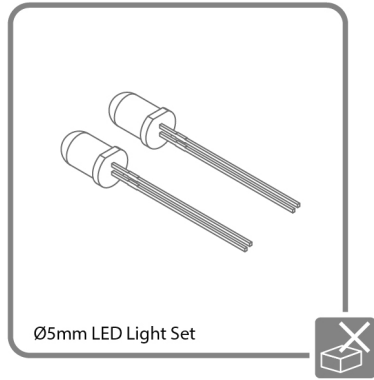

A CHASSIS



Bumper Light Retainer x 2
#BRX020032



M2x4 SC x 4
#BRASFCH2004

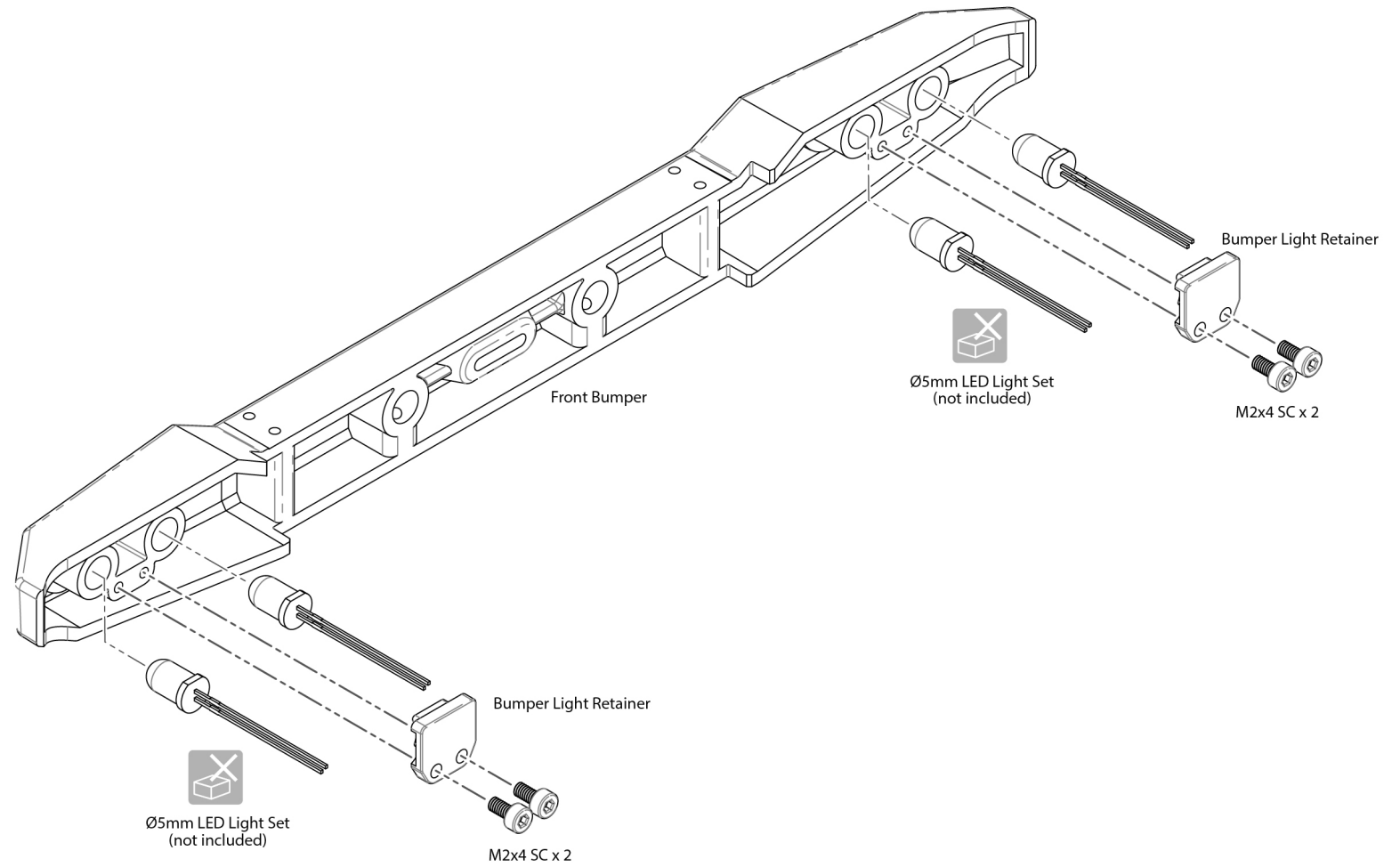

LED INSTALLATION

LED INSTALLATION

PRE-ASSEMBLED AXLE

Front Diff Cover Release Method In Case Assembly Is Tight.

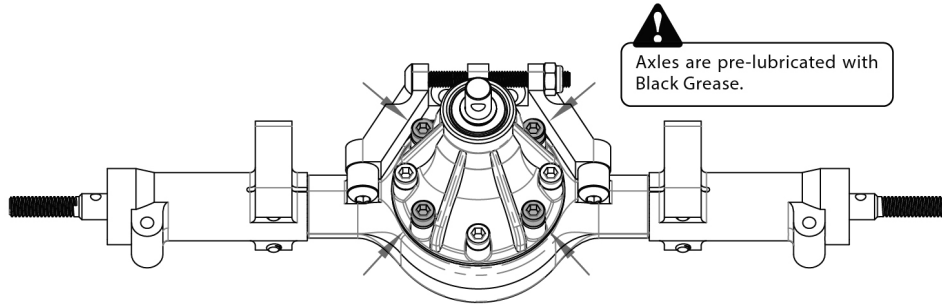

Step 1 - Loosen four M2.5x16mm socket screws indicated making the screw cap 3 mm apart from the case.

Step 2 - Hammer those screw slightly via screwdriver to release the front diff cover.

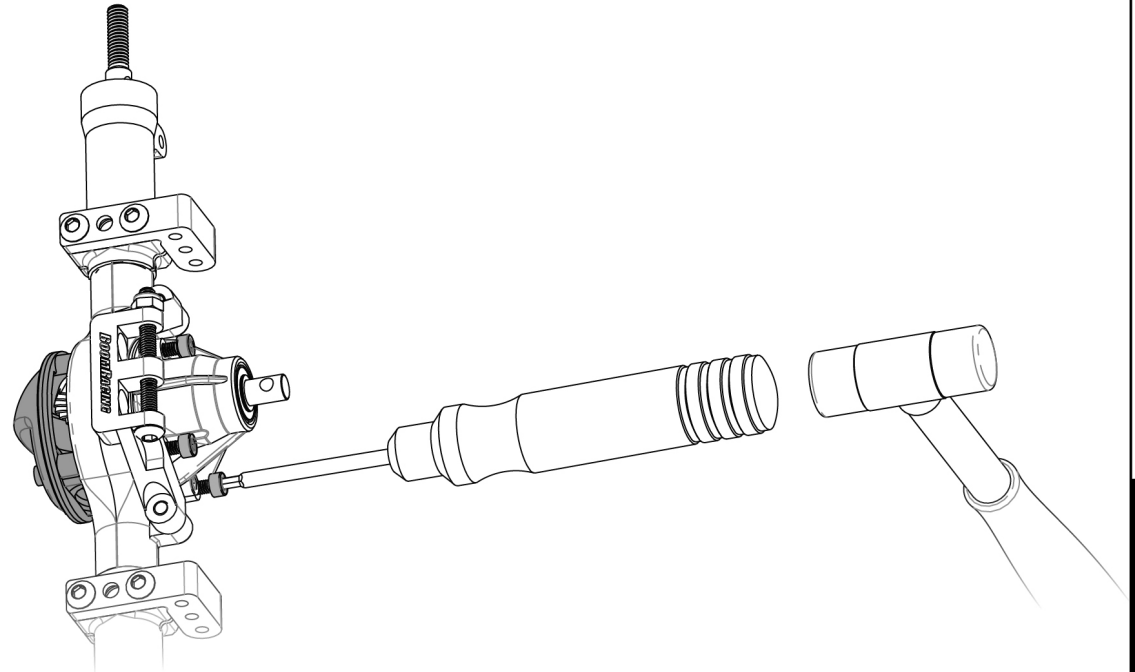

The Third Member Release Method When Assembly Is Tight.

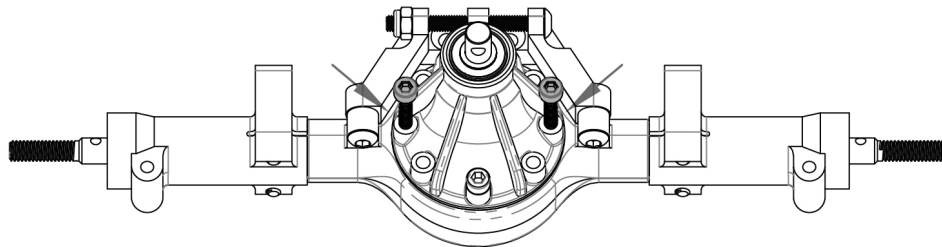

Step 1 - Remove all M2.5x16mm and two M2.5x5mm socket screws

Step 2 - Install two M2.5x16mm socket screws into both left and right screw holes as indicated

Step 3 - Lightly torque the screws until the third member is released

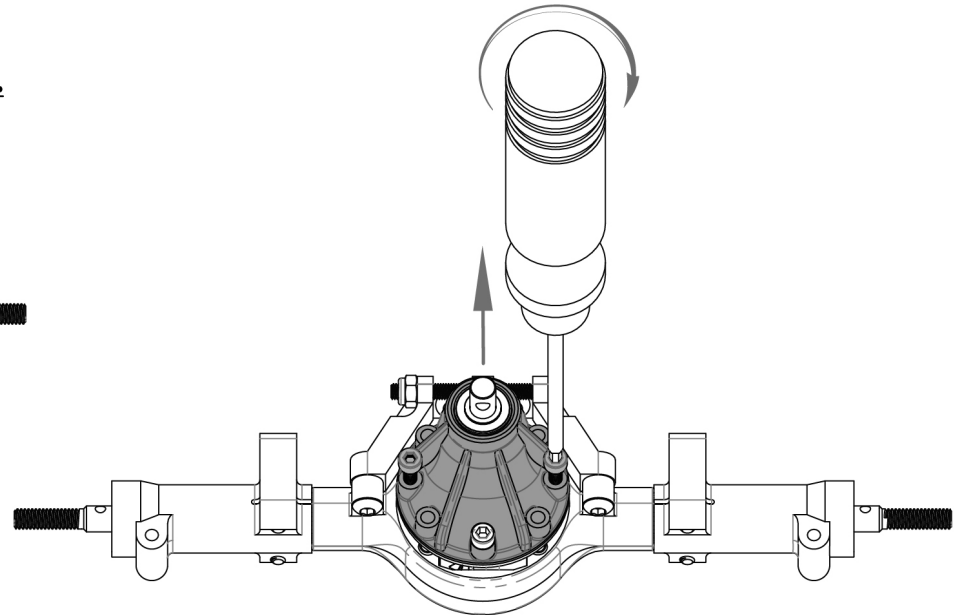

PRE-ASSEMBLED FRONT AXLE



Apply a generous amount of Black Grease on all movable contact surfaces including gears, spacers, shafts and bearings.

CNC Knuckle Lever - Right
#BRLC7002/A

M3x10 RS x 2
#BRASBH3010

D5x11x4 x 2
#BBZMR1152RS

Brass Knuckle Bushing x 4
#BRLC7022A

M3x16 RS x 4
#BRASBH3016

Leaf Spring Channel w/ Damper Mount
#BRLC7010

M2.5x16 SC x 4
#BRASCH2516

M2.5x5 SC x 3
#BRASCH2505

Cast Knuckle x 2
#BRLC7002/CA

M3x8 CSS x 2
#BRASFH3008

D10x15x4 x 2
#BBZ67002RS

D5x10x4 x 2
#BBZMR1052RS

Cast C-Hub x 2
#BRX020055

Bevel Helical Input Shaft 8T
#BR955020B

D5x11x4
#BBZMR1152RS

M2.5x10 SC x 2
#BRASCH2510

M3x10 RS x 2
#BRASBH3010

BRX70 / BRX90 PHAT™
Axle Third Member Cover
#BRLC7025

D5x14x5
#BBZ6052RS

Ultra Hard Steel Axle Universal Driveshaft x 2
#BRBD9001

M2x8 SC x 3
#BRASCH2008

Axle Housing
#BRLC7026A

Locker Spool
#BR955020C

M3x10 RS x 2
#BRASBH3010

OPTIONAL PART

M2x4 SC
#BRASCH2004

BRX70 / BRX90 PHAT™ Axle Black Diff Cover
#BRLC7026

D7x14x3.5 x 2
#BBZ687OPEN

CNC Knuckle Lever - Left
#BRLC7002/C



Bevel Helical Main Gear 30T
#BR955020A

#BR955029
HD Keyed Bevel Helical Overdrive Gear 27/8T +
Differential Locker Set

PRE-ASSEMBLED PARTS

PRE-ASSEMBLED PARTS

PRE-ASSEMBLED REAR AXLE

  Apply a generous amount of Black Grease on all movable contact surfaces including gears, spacers, shafts and bearings.

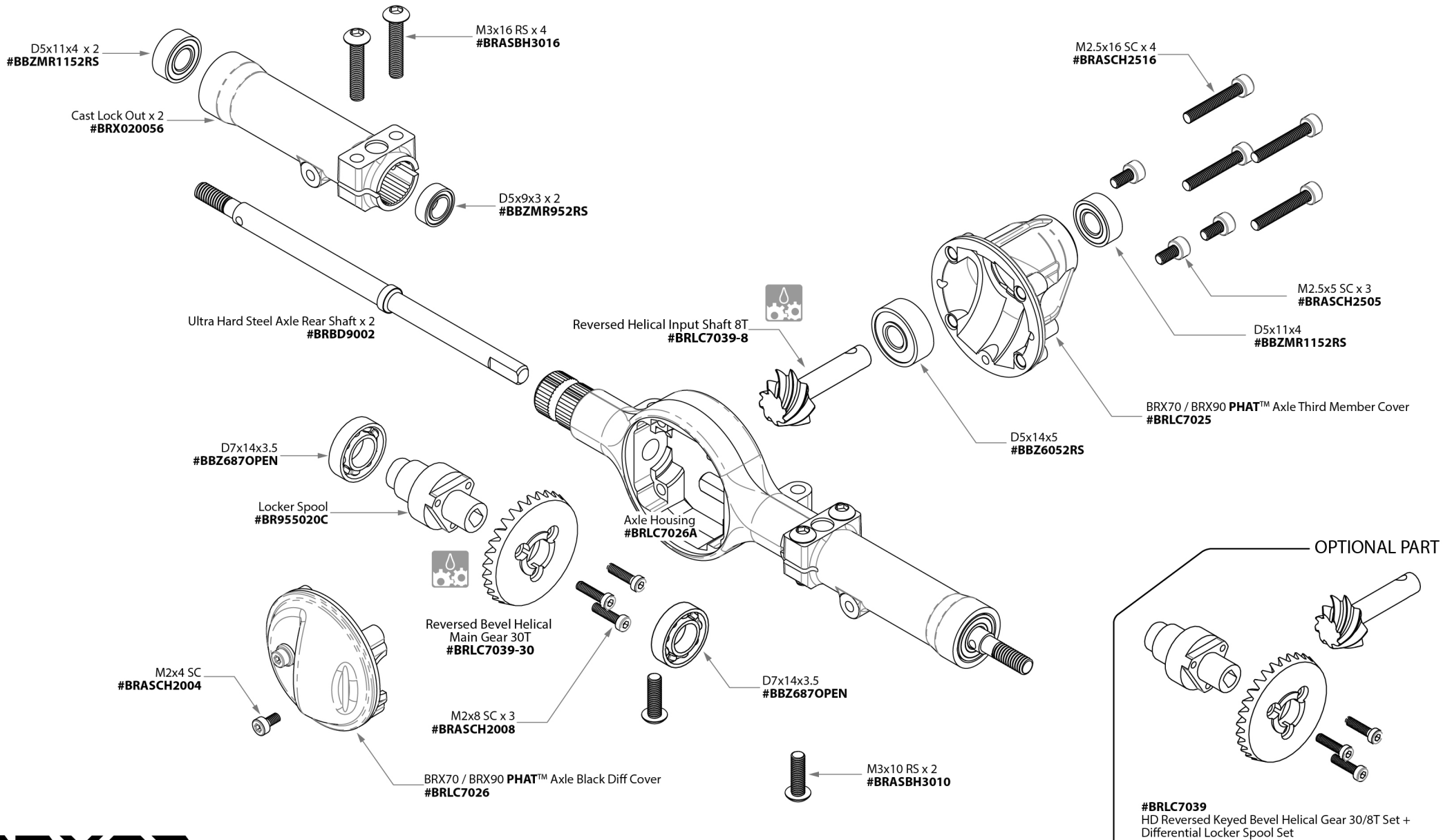

PRE-ASSEMBLED PARTS

PRE-ASSEMBLED PARTS

PARTS LIST

Part #	Description	Part #	Description
BBZ6052RS	5x14x5mm High Performance Rubber Sealed Bearing (1)	BRASSPD5801	Spacer D5x8x0.1 (10)
BBZ67002RS	10x15x4mm High Performance Rubber Sealed Bearing (1)	BRASSPD5805	Spacer D5x8x0.5 (10)
BBZ687OPEN	7x14x3.5mm High Performance Open Ball Bearing (1)	BRASSPD5730	Spacer D5x7x3 (5)
BBZMR1052RS	5x10x4mm High Performance Rubber Sealed Bearing (1)	BRASSPRING05510	Ø5mm Spring (4)
BBZMR1152RS	5x11x4mm High Performance Rubber Sealed Bearing (1)	BRASST3003	M3x3 Set Screw (10)
BBZMR1172RS	7x11x3mm High Performance Rubber Sealed Bearing (1)	BRASST3006	M3x6 Set Screw (10)
BBZMR952RS	5x9x3mm High Performance Rubber Sealed Bearing (1)	BRASST3022/DS	M3/2.2x11 Set Screw (10)
BR955020	Heavy Duty Keyed Bevel Helical Gear 30/8T + Differential Locker Spool Set	BRASST3024/DS	M3/2.4x11 Set Screw (10)
BR955020A	Heavy Duty Bevel Helical Main Gear 30T	BRASST4016	M4x16 Set Screw (10)
BR955020B	Heavy Duty Bevel Helical Input Shaft 8T	BRBD9001	Ultra Hard Steel Axle Universal Driveshaft (2)
BR955020C	Diff Locker Spool for HD Helical Bevel Gear	BRBD9002	Ultra Hard Steel Axle Rear Shaft (2)
BR955029	Heavy Duty Keyed Bevel Helical Overdrive Gear 27/8T + Differential Locker Set	BRD9022A	Stainless Steel Tie Rod
BRASBH2504	M2.5x4 RS Round Head Screw (10)	BRGRS01	BADASS™ Siliking Grease 5g
BRASBH2506	M2.5x6 RS Round Head Screw (10)	BRGRS08	BADASS™ Black Graphite Grease 5g
BRASBH2514	M2.5x14 RS Round Head Screw (10)	BRGRS09-5GB	BADASS™ Shock Slime Grease 5g
BRASBH3006	M3x6 RS Round Head Screw (10)	BRGRS10274-10	BADASS™ Silicone Grease 10g
BRASBH3008	M3x8 RS Round Head Screw (10)	BRGRS10274-20	BADASS™ Silicone Grease 20g
BRASBH3010	M3x10 RS Round Head Screw (10)	BRGRS1055-10	BADASS™ Black Graphite Grease 10g
BRASBH3012	M3x12 RS Round Head Screw (10)	BRGRS1055-20	BADASS™ Black Graphite Grease 20g
BRASBH3014	M3x14 RS Round Head Screw (10)	BRGRS242	242 Blue Thread Lock 10g
BRASBH3016	M3x16 RS Round Head Screw (10)	BRLC7002/A	Aluminum Knuckle Lever (High Clearance) for BRX70 / BRX90 Knuckle
BRASBH3022	M3x22 RS Round Head Screw (10)	BRLC7002/B	Aluminum Knuckle Arm (Low Profile) for BRX70 / BRX90 / AR44 Knuckle (2)
BRASBH3024	M3x24 RS Round Head Screw (10)	BRLC7002/CA	Cast Metal Knuckle (2)
BRASCH2004	M2x4 SC Shocket Cap Screw (10)	BRLC7010	Steel Leaf Spring Channel w/ Shock Mount for BRX70 / BRX90 Axle (2)
BRASCH2008	M2x8 SC Shocket Cap Screw (10)	BRLC7019	Side Gearbox Mount (Left & Right)
BRASCH2505	M2.5x5 SC Shocket Cap Screw (10)	BRLC7022A	Brass Bushing for BRX70 / BRX90 Axle Knuckle BRLC7022/BRD9022 (4)
BRASCH2506	M2.5x6 SC Shocket Cap Screw (10)	BRLC7025	BRX70 / BRX90 PHAT™ Axle Third Member Cover
BRASCH2508	M2.5x8 SC Shocket Cap Screw (10)	BRLC7026	BRX70 / BRX90 PHAT™ Axle Black Diff Cover
BRASCH2510	M2.5x10 SC Shocket Cap Screw (10)	BRLC7026A	BRX70 / BRX90 PHAT™ Axle Housing
BRASCH2516	M2.5x16 SC Shocket Cap Screw (10)	BRLC7027	Aluminum Gearbox Adapter w/ Motor Mount
BRASCH3008	M3x8 SC Shocket Cap Screw (10)	BRLC7029-12T	Heavy Duty 12T Spur Gear
BRASEC30	E-Clip 3mm (10)	BRLC7029-15T	Heavy Duty 15T Spur Gear
BRASFH2005	M2x5 CSS Counter Sunk Screw (10)	BRLC7029-20T	Heavy Duty 20T Spur Gear
BRASFH2508	M2.5x8 CSS Counter Sunk Screw (10)	BRLC7029-24T	Heavy Duty 24T Spur Gear
BRASFH3006	M3x6 CSS Counter Sunk Screw (10)	BRLC7029-32T	Heavy Duty 32T Spur Gear
BRASFH3008	M3x8 CSS Counter Sunk Screw (10)	BRLC7030	Spur Gear Mount
BRASFH3010	M3x10 CSS Counter Sunk Screw (10)	BRLC7031	Internal Spur Gear 28T
BRASHS3005	M3x5 Hex Cap Screw (2)	BRLC7032	Steel Motor Spacer
BRASNUTM25	Nut M2.5 (5)	BRLC7033	BRX Universal Receiver Box Set w/ Silicone Seals
BRASNUTM3	Lock Nut M3 Nyloc (5)	BRLC7033A	Silicone Seal & Port for BRX Receive Box
BRASNUTM4	Lock Nut M4 Nyloc (5)	BRLC7039	30/8T Reverse HD Steel Triangular Keyed Bevel Helical Cut Diff Gear w/ Spool Set for BRX70 / BRX90 Axle
BRASPIN210	D2x10 Pin (10)	BRLC7039-8	HD Steel Reversed Helical Input Shaft 8T
BRASSP473	D4x7x3 Aluminum Spacer (5)	BRLC7039-30	HD Steel Reversed Bevel Helical Main Gear 30T

PARTS LIST

Part #	Description	Part #	Description
BRLC7041	M3x6x3 Tapper Spacer (4)	BRX020007	Steering Servo Mount (2)
BRLC7044	Ultra Hard Steel Gearbox Shaft Set (3pcs)	BRX020009	Mini Servo Mount
BRLC7044A	Ultra Hard Steel Gear Catcher	BRX020011	Chassis Rail (Left & Right)
BRLC7044B	Input shaft	BRX020012	Rear Crossmember
BRLC7044C	Output Shaft	BRX020014	Mid Crossmember
BRLC7044E	2-Speed Gear Unit	BRX020015F	Front Bumper
BRLC7045A	Brass Shifter Cap & Bushing	BRX020015R	Rear Bumper
BRLC7045B	Ultra Hard Steel Shifter	BRX020016	Front Crossmember
BRLC7045C	Stainless Steel Shift Rod	BRX020017	Rear Gearbox Mount
BRLC7046	Heavy Duty Steel Cut Transfer Case Gears & Steel Shafts Set	BRX020018F	Front shock Mount (Left & Right)
BRLC7046-A	Input Shaft w/ 20T Spur Gear	BRX020018R	Rear Shock Mount (Left & Right)
BRLC7046-B	29T Spur Gear (2)	BRX020019	Rear Bumper Mount (Left & Right)
BRLC7046-C	Two Ends Output Shaft	BRX020020LF	Center Skid Plate
BRLC7046-D	One End Output Shaft	BRX020021	Battery Tray
BRLC7049	Mini Servo Horn	BRX020022LF	BRX90 Complete Front PHAT™ Axle LEAF Ver.
BRLC7050	Fine Tunable Link	BRX020023LF	BRX90 Complete Rear PHAT™ Axle LEAF Ver.
BRLC7055	Aluminum Long Low Profile Servo Horn 25T Black	BRX020027	Front Anti-wrap Bar (2)
BRLC7060	2-Speed Gear Circle Clip (5)	BRX020028	Steel Connection Drive Shaft (33mm)
BRLC7064A	Leaf Spring Set (2)	BRX020029	BCF2™ Gearbox Housing (A & B)
BRLC7064C	Stainless Steel M4X40 Anti-wrap Bar (2)	BRX020029A	Gear Box Bearing Holder
BRLC7064D	Rear Shackle (2)	BRX020030	Brass Washer (4)
BRLC7064E	M3x14 Bolt	BRX020032	Bumper Light Retainer (2)
BRLC7064F	Rear Leaf Retainer (Outside & inside) (2)	BRX020034	Body Latch Pin (4)
BRLC7095	Extension Cable (2)	BRX020035	Slider Spacer (4)
BRPG3212-3	32P 12T / 3.175mm Steel Pinion Gear	BRX020039	Body Post (4)
BRQ90351	D2 Ball & Rod End	BRX020043	KUDU™ HD CVD Center Drive Shaft (2)
BRSH0090	KUDU™ 90mm Scale Shock Absorber (2)	BRX020047	SRD™ Transfer Case Housing
BRSHJR	Pivot Ball Retainer (4)	BRX020051	Shift Rod
BRSORD6-15	D6x1.5 O-Ring (10)	BRX020055	Cast C-Hub (2)
BRT10037	Cable Wiring Retainer	BRX020056	Cast Lock Out (2)
BRT10028	Tool Kit	BRX020061	Quick Release Body Latch (2)
BRT10053	Pivot Ball Tool	BRX020062	Quick Release Body Mount (Left & Right)
BRTR19005	1.9" SP ROAD TRACKER™ Crawler Tire GEKKO Black 3.82"x0.94" (97x24mm) w/ Single Stage Open Cell Foam (2)	BRX020063	Quick Release Body Mount Extension (Left & Right)
BRTR39005	Single Stage Open Cell Foam Insert for 1.9" SP ROAD TRACKER™ Crawler Tire 3.82"x0.94" (97x24mm) (2)	BRX020064A	Front Shackle (2)
BRW750300	BADASS™ Stainless Steel Pivot Ball (10)	BRX020064B	Front Leaf Retainer (Left & Right)
BRW750306A	KUDU™ HD Rust-Resistant Rod Ends M4 Nylon (Straight) 18.5mm w/ SST Pivot Ball (5.8x3x7.4mm) (10)	BRX020072F	Front Center Skid Slider
BRW750309B	KUDU™ HD Rust-Resistant Rod Ends M4 Nylon (Straight) 21.8mm w/ SST Pivot Ball (5.8x3x7.4mm) (10)	BRX020072R	Rear Center Skid Slider
BRW750310	Shock End Pivote Ball (4)	BRX020079	ESC Mounting Plate
BRW780920	1.9" Narrow 16-Hole Classic Steelie Reversible Beadlock Wheels (Gun Metal) (2)	BRXT500V2	XT500 5-Lug Aluminum 12mm Wheel Pin Hub Adapters 0MM Offset V2 (2)
BRW780923	S100 Scale Center Wheel Hub Cap (2)	JX/PDI-HV1151MG	JX Waterproof High Voltage Mini Servo

PARTS LIST (Optional Accessories)

Part #	Description
Overdrive Gears	
BR955029	Overdrive HD Steel Keyed Bevel Helical Gear 27/8T & Diff Locker Spool Set
BR955029A	Overdrive HD Bevel Helical Main Gear 27T for BR955029
BR955029B	Overdrive HD Bevel Helical Input Shaft 8T for BR955029

Part #	Description
Pinion Gear	
BRPG3209-3	32P 9T / 3.175mm Steel Pinion Gear (1)
BRPG3210-3	32P 10T / 3.175mm Steel Pinion Gear (1)
BRPG3211-3	32P 11T / 3.175mm Steel Pinion Gear (1)
BRPG3213-3	32P 13T / 3.175mm Steel Pinion Gear (1)
BRPG3214-3	32P 14T / 3.175mm Steel Pinion Gear (1)
BRPG3215-3	32P 15T / 3.175mm Steel Pinion Gear (1)
BRPG3216-3	32P 16T / 3.175mm Steel Pinion Gear (1)
BRPG32COMBO1-3	32P Steel Pinion Gear Combo 9T-12T (4)
BRPG32COMBO2-3	32P Steel Pinion Gear Combo 13T-16T (4)

Part #	Description
Shock Oil	
BRSHK010	BADASS™ Silicone Shock Oil 10wt 60ml
BRSHK015	BADASS™ Silicone Shock Oil 15wt 60ml
BRSHK020	BADASS™ Silicone Shock Oil 20wt 60ml
BRSHK025	BADASS™ Silicone Shock Oil 25wt 60ml
BRSHK030	BADASS™ Silicone Shock Oil 30wt 60ml
BRSHK035	BADASS™ Silicone Shock Oil 35wt 60ml
BRSHK040	BADASS™ Silicone Shock Oil 40wt 60ml
BRSHK045	BADASS™ Silicone Shock Oil 45wt 60ml
BRSHK050	BADASS™ Silicone Shock Oil 50wt 60ml
BRSHK055	BADASS™ Silicone Shock Oil 55wt 60ml
BRSHK060	BADASS™ Silicone Shock Oil 60wt 60ml
BRSHK065	BADASS™ Silicone Shock Oil 65wt 60ml
BRSHK070	BADASS™ Silicone Shock Oil 70wt 60ml
BRSHK075	BADASS™ Silicone Shock Oil 75wt 60ml
BRSHK080	BADASS™ Silicone Shock Oil 80wt 60ml

Part #	Description
Bearing Set	
BRX01BBZ	High Performance Full Ball Bearings Set Rubber Sealed (32 Total)
BRX01FABBZ	High Performance Ball Bearings Set Rubber Sealed For Front Axle (10 Total)
BRX01GBBBZ	High Performance Ball Bearings Set Rubber Sealed For Gearbox (8 Total)
BRX01RABBZ	High Performance Ball Bearings Set Rubber Sealed For Rear Axle (8 Total)
BRX01TCBBZ	High Performance Ball Bearings Set Rubber Sealed For Transfer Case (6 Total)

If you have questions, call Boom Racing at:
1-209-676-8880 (USA) or email Boom Racing at sales@boomracingrc.com

WWW.BOOMRACINGRC.COM

1.9" MILEAGE CLASSIC SCALE CRAWLER TIRE GEKKO COMPOUND
3.82"x1.0" (97x26mm)

#BRTR19006



ROCK MONSTER RED SILICONE TIRE INSERT
3.5"x0.84" (90x21mm)
FOR 1.9" MILEAGE CLASSIC / SP ROAD TRACKER

#BRRM19006



1.9" TPD ALL-TERRAIN CRAWLER TIRE GEKKO COMPOUND
3.82"x1.3" (97x33mm)

#BRTR19008



MUSCLE WINCH™
HIGH TORQUE 36KG
WATERPROOF SERVO WINCH
W/ FREE SPOOL UNIT
#BR-36SW



DIG
#BRD90101-DG

OVERDRIVE
#BRLC70201-OD



TRANSFER CASE KITS

SWD (SELECTIVE RWD/4WD)
#BRD90301-SWD



MINI SERVO MOUNT KIT

#BRD90110064KIT
(with Mini Servo)

#BRD90110065
(without Mini Servo)



WINCH MOUNT & LEAD KIT
FOR MUSCLE WINCH™
#BRD90110036



OPTIONAL PARTS



WATERPROOF ALUMINUM LED LIGHT BAR SET (3S CAPABLE)



#BRTL145 (145mm)

#BRTL50 (50mm)

#BRTL90 (90mm)

HEAVY DUTY KEYED BEVEL HELICAL OVERDRIVE GEAR + DIFFERENTIAL LOCKER SET FOR BRX70/BRX90/AR44/AR45 AXLES



24/8T
#BR955040

27/8T
#BR955029

BRASS FRONT KNUCKLE BASE WEIGHTS FOR BRX70/BRX90/AR44 PHAT AXLE



BRASS FRONT KNUCKLE BASE WEIGHTS
#BRLC7089

BRASS REAR KNUCKLE BASE WEIGHTS FOR BRX90 PHAT AXLE #BRD9024



BRASS SMALL WEIGHT BLOCKS 4G
#BRLC7092

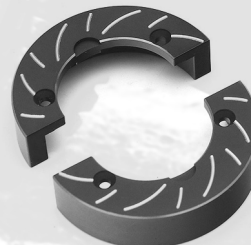

BRASS LARGE WEIGHT BLOCKS 23G
#BRLC7091

OPTIONAL PARTS

GEARBOX COMPARTMENT

There are only two D110 hard bodies that are compatible with the BRX02 D110 chassis – Team Raffee Co. #TRC/302214 and #TRC/302215. The modifications below are for those who might already have a Team Raffee Co. D110 body in the past. The bodies available for purchase after the release of the BRX02 are all updated and do not require the following modifications.

Stick the template down onto the bottom of the interior floor in the steps as shown starting at the front. Then, cut away the grey marked area.

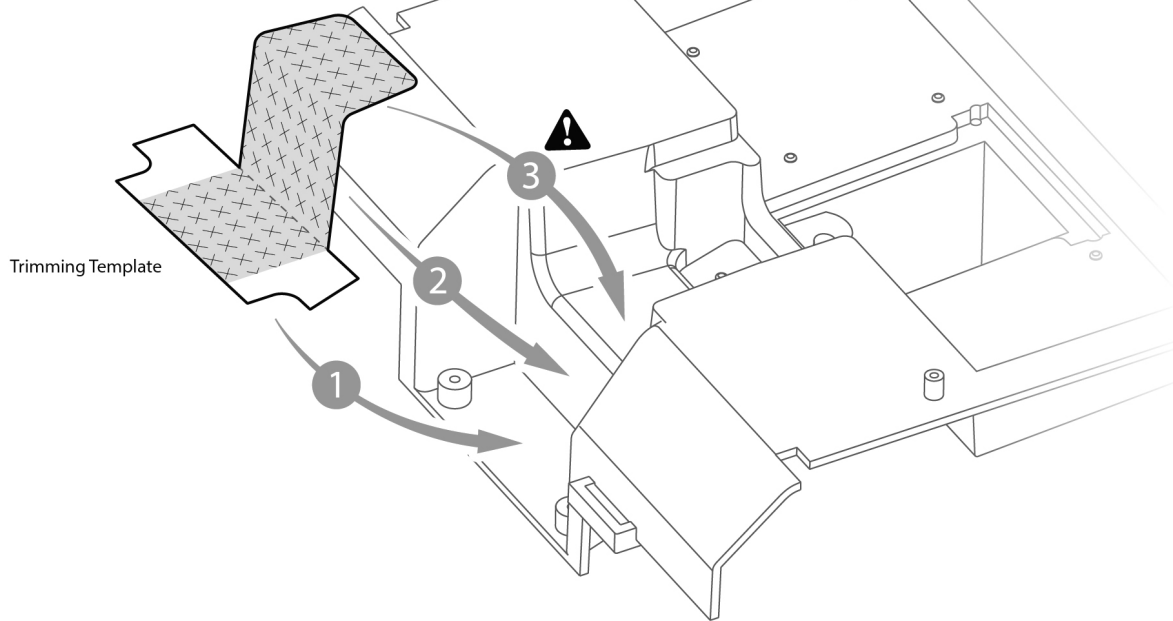

Trimming Template

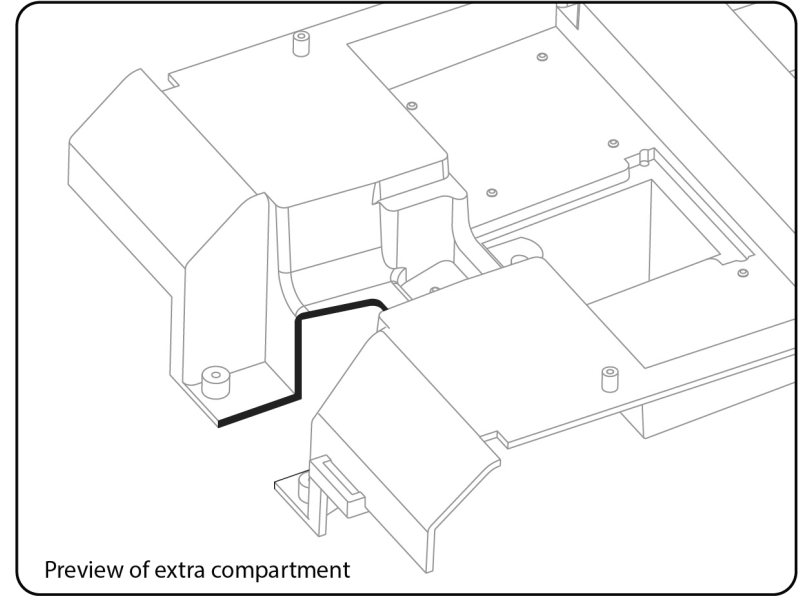

Preview of extra compartment

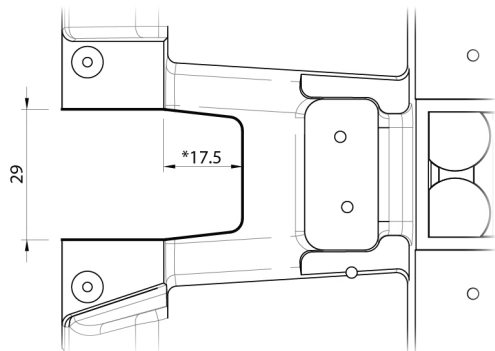

*Make sure not to remove more than 17.5mm deep on the face (3) of the Trimming Template. Otherwise, a gap may appear from the interior.

Trimming Template

Cut along the dotted line for template.

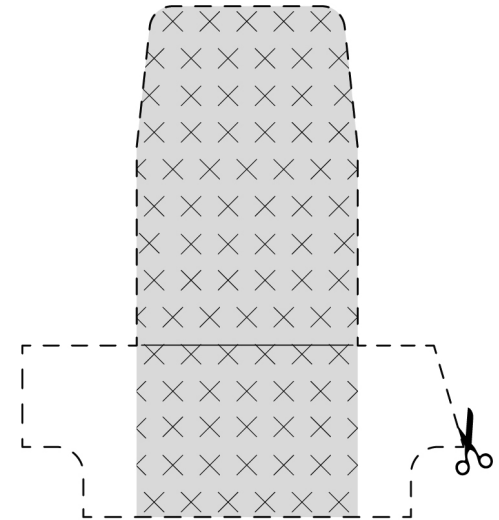

NOTES

Kristian Dubiel (Snakepit RC)

The BRX02 isn't just a BRX01 with a longer wheelbase. Rather, it is the further development of what I consider to be the best scale chassis on the market. The new KUDU™ shocks, KUDU™ drive shafts, the carbon chassis rails and the quick-release body mount take the BRX02 to an even higher level. The BRX02 is a "must have" for every Defender fan out there and the best base for your next Defender build. You won't find a chassis out-of-the-box that works as well as the BRX02.

My first test drive was a Trophy event with many goals and difficult terrain. The BRX02 worked perfectly right from the start and had very good performance, as well as a fantastic driving image which rewarded me with a first-place finish.

Shawn Roche (USA)

I almost gave up trying to find a kit that has the correct balance of scale, quality and performance. But once I got my hands on the BRX02 I knew instantly that Boom Racing got it right, and having a tool free quick release on a hard body is amazing.

Andreas Briesemeister / Stefan Lindenau (Germany)

The BRX02 is not just a successor or a copy of the BRX01 - it's a complete new chassis. Everything fits together harmoniously, and it is fun to drive. The handling is very convincing despite the heavy Defender body. The quality of the materials used is very high standard, leaving nothing to be desired. The carbon frame visually pleases the eyes. The new dampers are eye-catching and work precisely and smoothly with the low friction sealing o-rings. The three different spring rates supplied offer adjustability for different setups. With the quick-release body mount, the change of the battery happens in a few seconds. You can easily separate the body from the chassis by compressing just two tabs. BRX02 will be more successful, and it is designed for a whole different target group.

Joe Conti (Malta)

Assembling the BRX02 is as easy and as much fun as assembling the BRX01. One can very easily see the quality of this product. The parts fit together very well and this shows the thought that went into designing it. The new features make the BRX02 that much better; the new shocks, the new drive shafts, carbon fiber chassis rails and the new body mounts. The new body mount makes installing and removing the body much easier than ever, there is nothing like it out there.



BOOMRACING®
Your Radio Control Car Specialist

BRX02

1/10 4WD RADIO CONTROL CHASSIS KIT FOR D110

WWW.BOOMRACINGRC.COM